

HULTDINS TM
SuperSaw

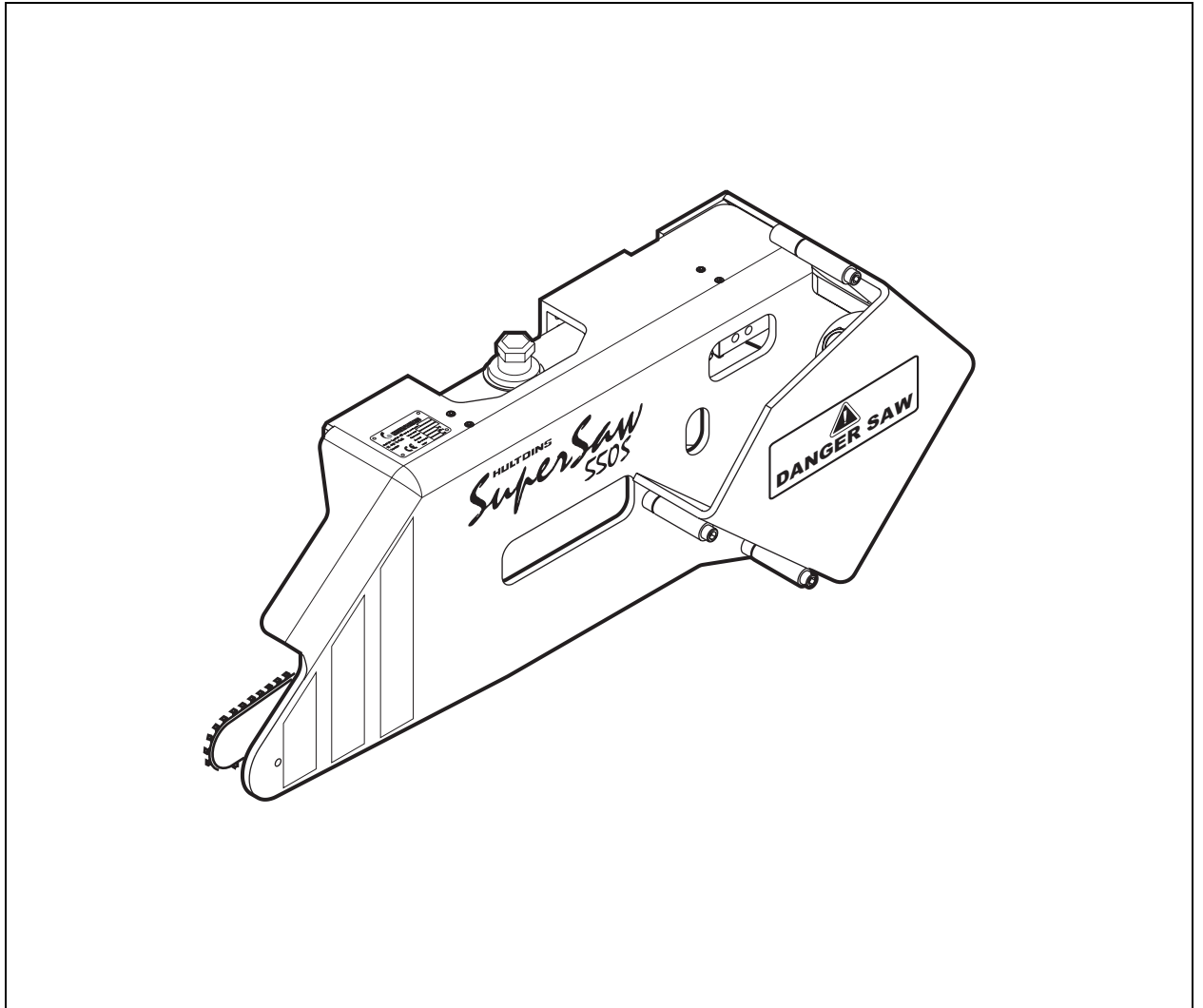

SuperSaw 550S

**Service manual
S/N 031-484 and up**

This publication contains instructions for the maintenance of the *SuperSaw 550S* grapple saw units. The instructions cover general information, procedures and specifications applicable to this grapple saw. If doubt should arise concerning the validity of the instructions please consult the nearest dealer for more detailed information.

Illustrations, technical information and specifications were, as far as we have been able to judge, correct at the time of print. However, we reserve the right to, without prior notice, revise specifications, instructions, equipment, etc. as a result of ongoing product improvement activities.

No part of this publication may without approval of HULTDIN SYSTEM AB be translated, reproduced, stored or transmitted electronically, mechanically, photographically or in another way not specified here.

Even if all conceivable measures have been taken to make the contents as complete as possible, HULTDIN SYSTEM AB takes no responsibility for possible damages that may arise as a result of the instructions not being followed or improper use of the product.

 **Important!**

The parts and components used in HULTDIN SYSTEM AB's products are specifically chosen. Therefore original spare parts are always the best alternative in a possible need of repairs or upgrading.

All service and repairs should be carried out by qualified service personnel or an authorized repair shop with suitable tools and lifting devices.

This publication is published by: HULTDIN SYSTEM AB
Skolgatan 12
SE-930 70 Malå
SWEDEN

Contents	Page	Contents	Page
Safety instructions	5	Manual chain tensioning	38
Welding	6	Replacing broken guide screw	39
Modifying the equipment.....	6	Replacing piston seals	40
System overview	7	Replacing piston rod seal	41
Product description	9	Testing function of check valve	42
Technical data	11	Replacing tension- and lub. oil hoses.....	42
SuperSaw 550S / TL.....	11	Maintenance instructions	43
SuperSaw 550S / SG	13	Regular maintenance.....	43
Special tools	15	Daily maintenance	43
Air Pump	15	Every 250 hours of operation	43
Combi Wrench.....	15	Every year of operation	43
Standard tools.....	16	Lubrication	44
Wrenches	16	Fastener joints and hydraulic hoses	44
Allen keys.....	16	The first month of operation	44
Hydraulic Diagram SuperSaw 550S/TL	17	Fasteners	44
Hydraulic Diagram SuperSaw 550S/SG	18	Troubleshooting	45
Functional description	19	SuperSaw 550S.....	45
Saw activated chain tensioning	19	SuperCut	46
Pressure line feed out system	20		
Lubrication system	21		
Assembly and Disassembly	22		
Installing the SuperSaw 550S on TL grapples...	22		
Installing the SuperSaw 550S on SG grapples...	24		
Adjusting chain tension pressure	27		
Adjusting saw bar feed out pressure	28		
Adjusting saw bar retraction	29		
Charging the air tank	29		
Depressurizing the air tank.....	30		
Replacing Accumulator.....	31		
Refilling lubrication oil tank	32		
Bleeding chain tension system.....	33		
Saw activated tensioning	33		
Constant pressure activated tensioning	34		
Bleeding chain lubrication system	34		
Replacing saw chain.....	35		
Replacing saw bar	36		
Replacing bar holder	37		

CONTENTS

(This page left empty for possible future additions)

Safety instructions

This page describes important safety instructions, which the operator's of Hultdins SuperFell, SuperSaw and SuperCut attachments should have a good knowledge of before the equipment is used.

The service manual should be available at all times so that the operator is able to follow safety regulations and the procedures of maintenance activities..

Note! Read carefully and understand the following information with concerns to safe operation practices before operating this equipment.

Important!

The owner and the operator are responsible for following all safety regulations and that the machine is safely equipped.

Important!

Check the machine for damages at the beginning of each shift.

Important!

Inspect and lubricate the unit at the beginning of each shift. Tighten all fasteners regularly.

Important!

All service and repairs should be carried out by qualified personnel or an authorized repair shop with suitable tools and lifting devices.

Important!

When working on the saw chain always ensure the engine is shut off and wear safety gloves to prevent injuries. Remove the saw chain when making any adjustments or servicing the saw unit.

Important!

Never adjust any hydraulic pressures without using a pressure gauge.

Important!

Consider the environment. Plug all connections to avoid unnecessary spill of oil.

Warning!

The hydraulic input of the equipment must not exceed the recommended maximum rating as structural failure could occur, resulting in injury and damaged equipment.

Warning!

Before performing any maintenance or service work, lower the attachment to the ground and shut off the engine. Turn off any master shut-offs and do not allow personnel in the cab.

Warning!

Keep all windows and doors securely closed when operating.

Warning!

Never touch or stand close to the pressurized cylinders and hydraulic hoses.

Warning!

The attachment has sharp edges. Use proper wrenches and protective gloves when working on the attachment.

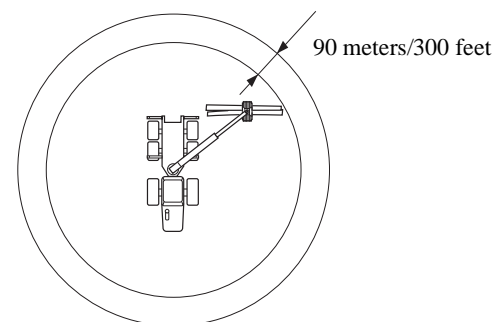

Fig. 1 The operating area of the saw attachment and the recommended safety distance

Warning!

When operating this equipment ensure all other personnel remain at least 300 feet clear of the machine. Turn the machine off immediately if anyone enters this safety zone.

Warning!

Training or demonstration of this equipment should be performed from an operator's cab approved by national regulations. Observers should always remain at least 300 feet away.

Warning!

Always use High Speed saw chains with 3/4" pitch saw units.

Welding

In case of a structural repair of the equipment, when welding may be needed, consult the dealer for recommended instructions.

When welding on the attachment the following steps must be taken:

- Make sure that fire-extinguishing equipment is available.
- Clean the area around the welding area to eliminate any fire hazard.
- Connect the ground wire so the welding current does not pass over any bushings.
- Place the ground wire as close to the welding area as possible.

Modifying the equipment

It is not approved to:

- Modify the equipment without the consent of HULTDIN SYSTEM AB.
- Alter the function of the equipment without the consent of HULTDIN SYSTEM AB.
- Use spare parts other than original HULTDINS parts.

System overview

The *SuperSaw 550S* is made up of the following main parts. All parts are replaceable.

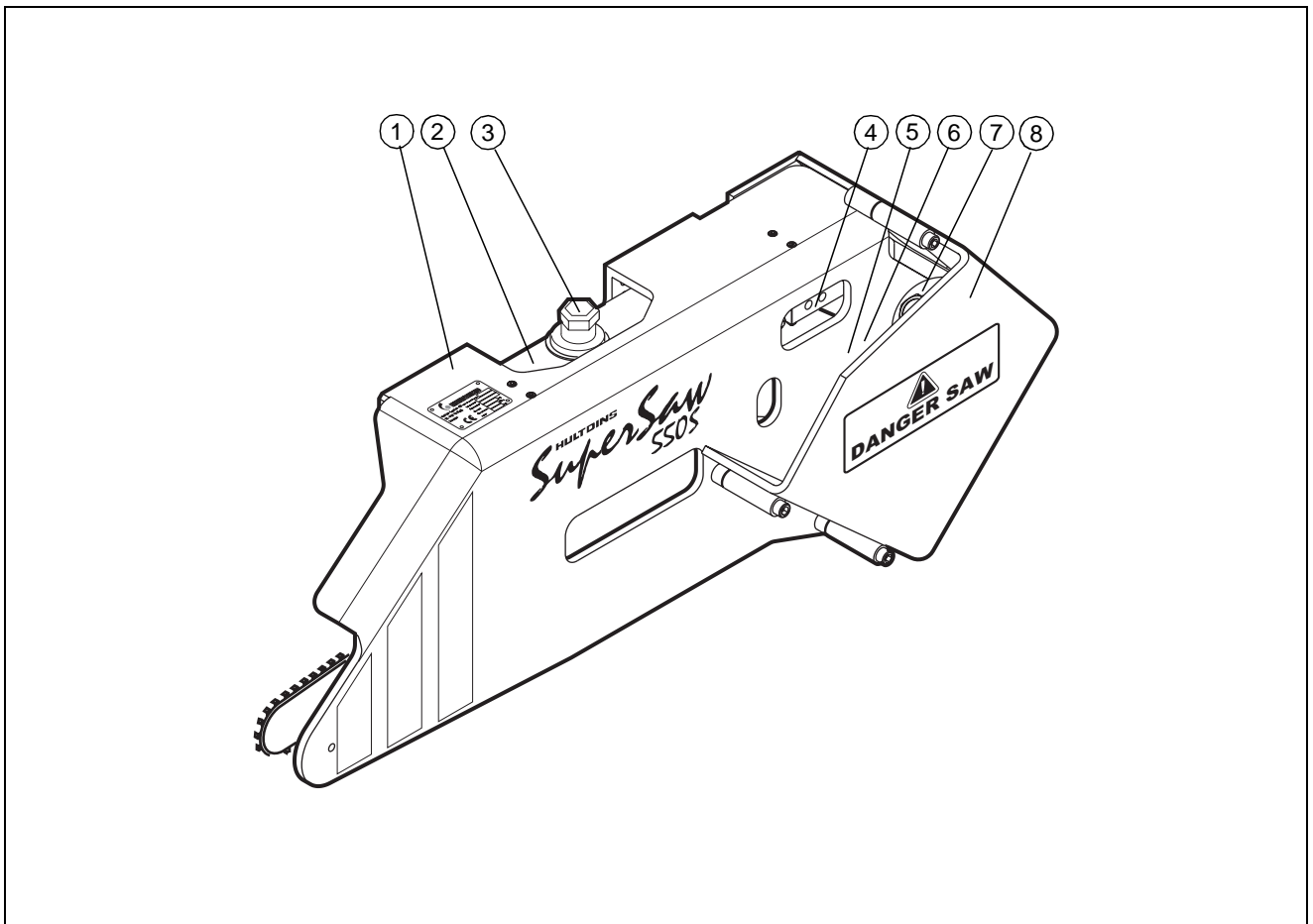

Fig. 2 System overview

- | | |
|-----------------------------|--|
| 1 Frame | 6 Saw motor with manifold |
| 2 Lubrication oil tank | 7 Accumulator for saw motor case drain |
| 3 Filler cap | 8 Saw motor cover |
| 4 Pressure regulating valve | |
| 5 Saw unit | |

System overview

The *SuperCut 0703853/0703860* is made up of the following main parts. All parts are replaceable.

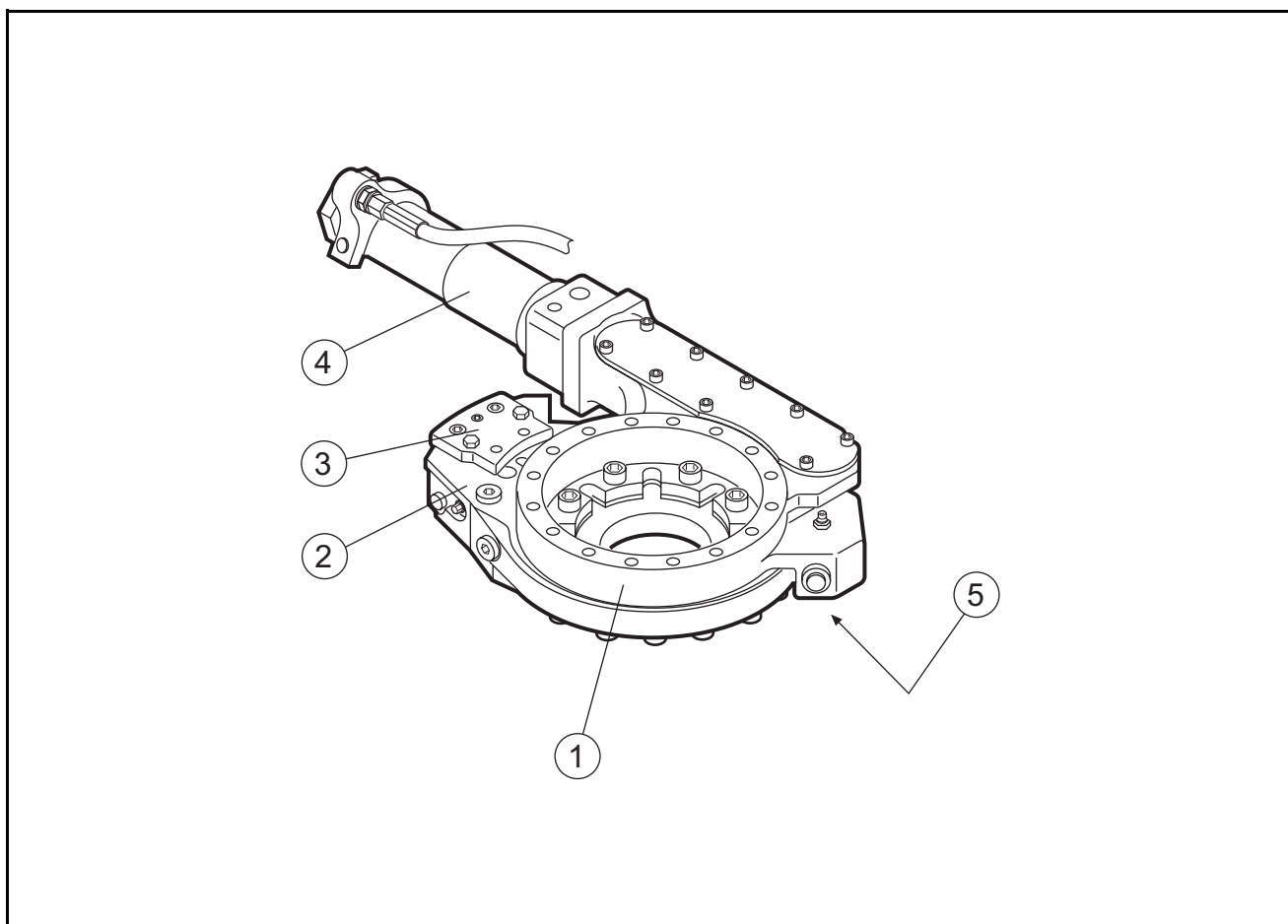

Fig. 3 System overview

- 1 Saw stand
- 2 Tensioning device
- 3 Bar holder
- 4 Feed out cylinder
- 5 Lubrication oil pump with cam curve

Product description

The *SuperSaw 550S* grapple saw is generally mounted together with SuperGrip or SuperGrip TL grapples on log loaders, excavators etc.

The *SuperSaw 550S* grapple saw is only intended to be used for timber, in whole-tree, tree length, and waste wood systems.

Labeling

The *SuperSaw 550S* is labeled with a product sign, serial number, warning signs and an identification sign according to the following figure.

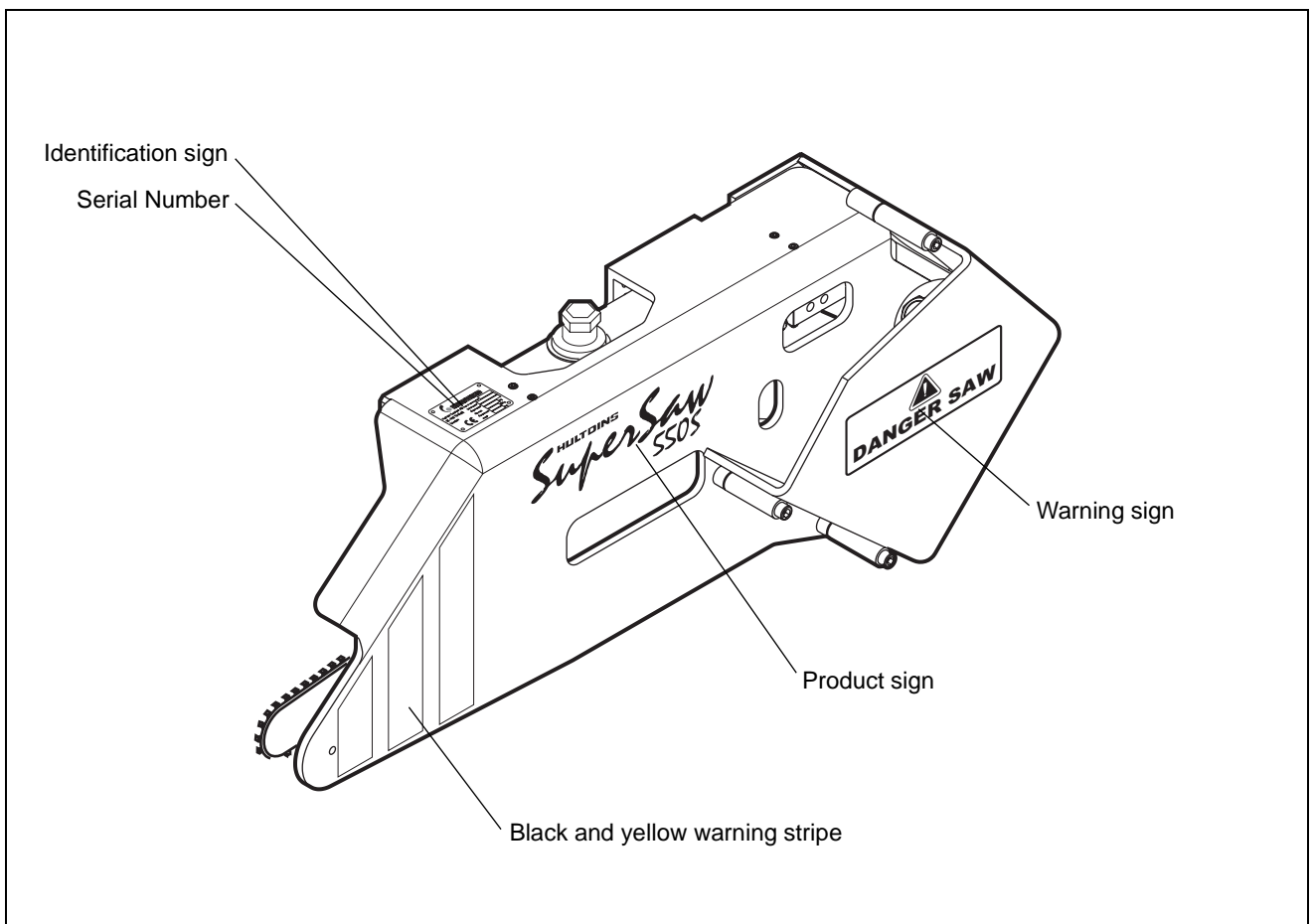

Fig. 4 Labeling *SuperSaw 550S*

Product description

Together with its range of accessories, Hultdins patented *SuperCut 0703853/0703860* saw unit is a comprehensive alternative for all applications with demands on functionality, reliability, service-friendliness, economy and the environment.

SuperCut 0703853/0703860 is a complete unit with integrated feed cylinder, well protected from external damage. It has been designed for use with hydraulic motors of the type VOAC F11 - 10 or, alternatively, F11 - 19. The saw motor bracket is assembled in ball bearings in the saw unit so that the hydraulic motor is stationary when the saw is fed out. The saw bar is returned either pneumatically by an accumulator or hydraulically with oil.

In its standard version, the *SuperCut 0703853/0703860* is equipped with automatic hydraulic chain tensioning and cam controlled mechanical lubrication pump that distributes lubricant to the chain during the complete sawing operation.

The mechanical lubrication pump delivers a maximum volume of 6 ml and the process can easily be adapted to specific lubricating requirements with a number of different cams. All the lubrication oils found on the market can be used.

All this in combination gives good saw bar, chain and oil economy.

With the accessories that are available for the *SuperCut 0703853/0703860*, you can easily design an integrated unit consisting of the saw unit, cam, saw motor, saw motor manifold, pressure regulating valve kit and drive sprocket kits.

Air and lubrication oil tanks are available as extra accessories and the *SuperCut 0703853/0703860* can be equipped with a saw home detector sensor and a cut control kit as options. The cut control kit is used in combination with a computerized bucking device and limits the angle to which the saw bar is fed out in relationship to the diameter of the tree.

Labeling

The *SuperCut 0703853/0703860* is labeled with serial number according to the following figure. See Fig. 5.

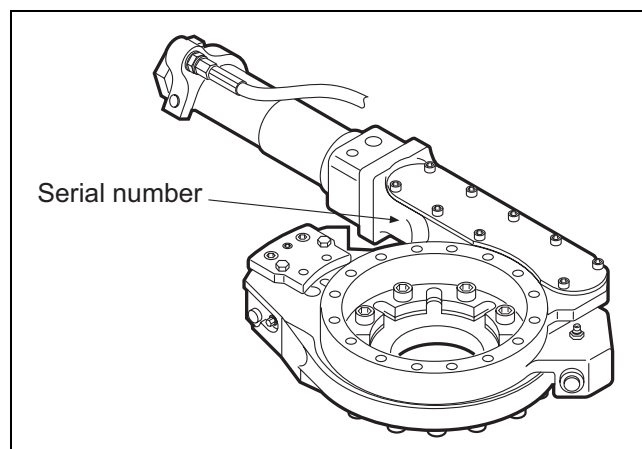

Fig. 5 Labeling *SuperCut 0703853/0703860*

Technical data

SuperSaw 550S / TL

	SuperSaw 550S / TL
Saw motor displacement.....	1.16 cu.in. (19 cm ³)
Weight	xxx lb. (xxx kg)
Weight with bracket.....	xxx lb. (xxx kg)
Length (A).....	45.47 in. (1155 mm)
Width (B)	8.23 in. (209 mm)
Height (C)	17.76 in. (451 mm)
Width (D)	5.79 in. (147 mm)
Saw bar and chain.....	.404 pitch
Chain tension	Automatic
Chain lubrication.....	Proportional

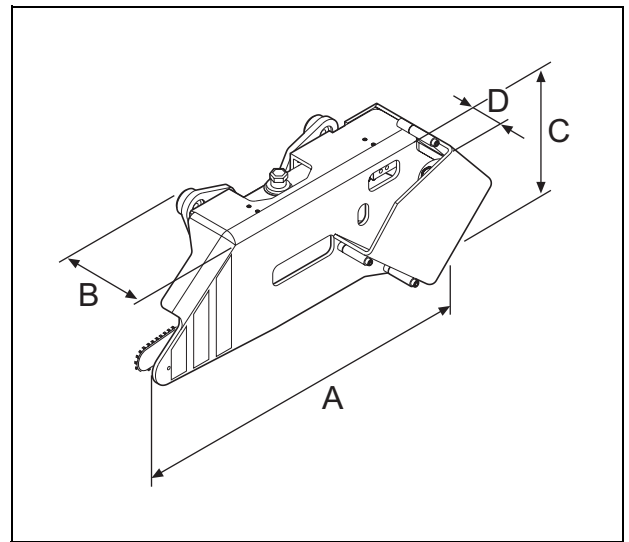

Fig. 6 Dimensions

Hydraulic pressures and flowes

Hydraulic pressure (saw motor).....	16 - 31 MPa (2300 - 4500 Psi)
Hydraulic flow (saw motor).....	120 - 220 lpm (31 - 58 GPM)
Hydraulic pressure (chain tensioning)	2.0 - 2.5 MPa (290 - 362 Psi)
Hydraulic pressure (saw bar feed out)	3.8 - 4.2 MPa (550 - 610 Psi)
Air pressure (saw bar retraction)	1.2 - 1.4 MPa (175 - 200 Psi)
Gas pressure (accumulator)	0.1 MPa (14.5 Psi)
Max. saw chain speed	See recommendations from each saw chain manufacturer.
Max. power input to saw chain.	See recommendations from each saw chain manufacturer.

Torque and socket/wrench sizes

Hex head Cap Screws			Torque	Wrench size
M6S	5	8.8	4.3 FT.LB. (5.7 Nm)	8 mm
M6S	6	8.8	7.4 FT.LB. (9.8 Nm)	10 mm
M6S	12	8.8	61 FT.LB. (81 Nm)	18 mm
M6S	20	8.8	406 FT.LB. (541 Nm)	30 mm

Socket head Cap Screws			Torque	Socket size
MC6S	5	12.9	7.3 FT.LB. (9.7 Nm)	4 mm
MC6S	6	12.9	12.8 FT.LB. (17 Nm)	5 mm
MC6S	8	12.9	30 FT.LB. (40 Nm)	6 mm
MC6S	10	12.9	59 FT.LB. (79 Nm)	8 mm
MC6S	12	12.9	102 FT.LB. (136 Nm)	10 mm
MC6S	16	12.9	250 FT.LB. (333 Nm)	14 mm
MC6S	20	12.9	487 FT.LB. (649 Nm)	17 mm

Nuts		Torque	Wrench size
M6M	16		24 mm
M6M	20	Loc-king	30 mm

Grease and Loc-tite

Grease	Use a water free grease with lithium, molybdenum or silicone additive. The abilities of the grease should include excellent water durability and antirust capabilities as well as good adhesive abilities and mechanical stability. NLGI Class 2.
Thread sealant	Loc-Tite 270

Greasing intervals

Every 8 to 200 hours of operation depending on the conditions that the unit is working under.

Technical data

SuperSaw 550S / SG

	SuperSaw 550S / SG
Saw motor displacement.....	1.16 cu.in. (19 cm ³)
Weight	xxx lb. (xxx kg)
Weight with bracket.....	xxx lb. (xxx kg)
Length (A).....	45.47 in. (1155 mm)
Width (B)	14.53 in. (369 mm)
Height (C)	17.76 in. (451 mm)
Width (D)	5.79 in. (147 mm)
Saw bar and chain.....	.404 pitch
Chain tension	Automatic
Chain lubrication.....	Proportional

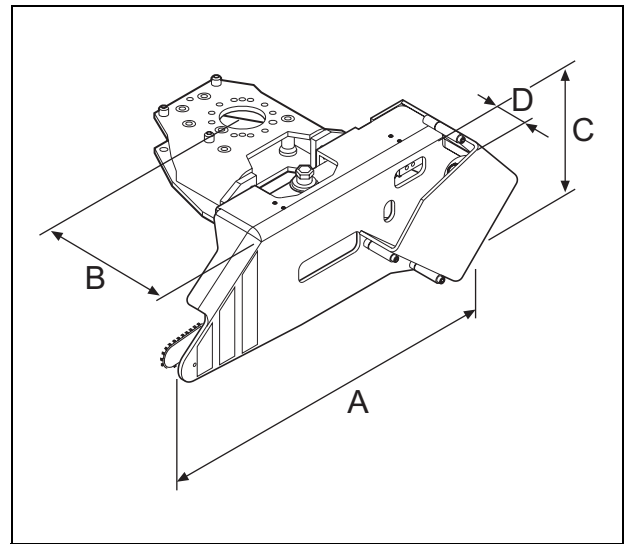

Fig. 7 Dimensions

Hydraulic pressures and flowes

Hydraulic pressure (saw motor).....	16 - 31 MPa (2300 - 4500 Psi)
Hydraulic flow (saw motor).....	120 - 220 lpm (31 - 58 GPM)
Hydraulic pressure (chain tensioning)	2.0 - 2.5 MPa (290 - 362 Psi)
Hydraulic pressure (saw bar feed out)	3.8 - 4.2 MPa (550 - 610 Psi)
Air pressure (saw bar retraction)	1.2 - 1.4 MPa (175 - 200 Psi)
Gas pressure (accumulator).....	0.1 MPa (14.5 Psi)
Max. saw chain speed.....	See recommendations from each saw chain manufacturer.
Max. power input to saw chain.	See recommendations from each saw chain manufacturer.

Torque and socket/wrench sizes

Hex head Cap Screws			Torque	Wrench size
M6S	5	8.8	4.3 FT.LB. (5.7 Nm)	8 mm
M6S	6	8.8	7.4 FT.LB. (9.8 Nm)	10 mm
M6S	12	8.8	61 FT.LB. (81 Nm)	18 mm
M6S	20	8.8	406 FT.LB. (541 Nm)	30 mm
Socket head Cap Screws			Torque	Socket size
MC6S	5	12.9	7.3 FT.LB. (9.7 Nm)	4 mm
MC6S	6	12.9	12.8 FT.LB. (17 Nm)	5 mm
MC6S	8	12.9	30 FT.LB. (40 Nm)	6 mm
MC6S	10	12.9	59 FT.LB. (79 Nm)	8 mm
MC6S	12	12.9	102 FT.LB. (136 Nm)	10 mm
MC6S	16	12.9	250 FT.LB. (333 Nm)	14 mm
MC6S	20	12.9	487 FT.LB. (649 Nm)	17 mm
Nuts			Torque	Wrench size
M6M	16			24 mm
M6M	20	Loc-king		30 mm

Grease and Loc-tite

Grease	Use a water free grease with lithium, molybdenum or silicone additive. The abilities of the grease should include excellent water durability and antirust capabilities as well as good adhesive abilities and mechanical stability. NLGI Class 2.
Thread sealant	Loc-Tite 270

Greasing intervals

Every 8 to 200 hours of operation depending on the conditions that the unit is working under.

Technical data

Special tools

The following special tools are required when servicing the SuperSaw 550S grapple saw.

Air Pump

The air pump is required when charging the air tank for the saw bar retraction. *See Fig. 8.*

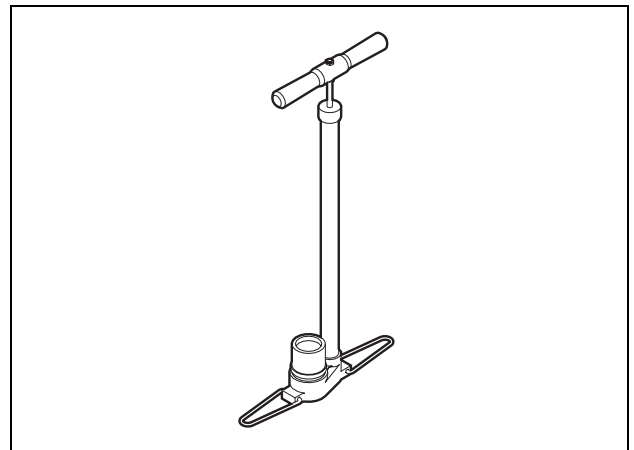

Fig. 8 Air Pump, P/N 0138042

Combi Wrench

The combi wrench has two wrench sizes, 16mm and 7mm. *See Fig. 9.*

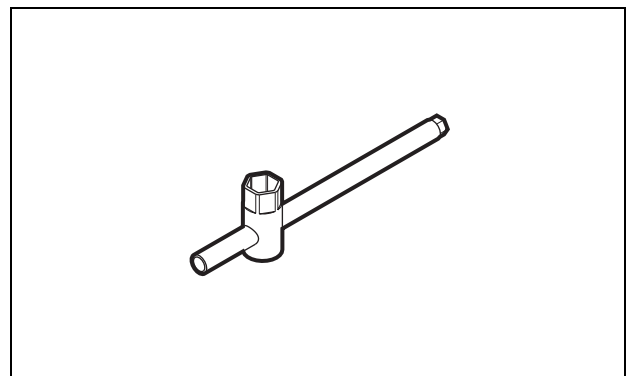

Fig. 9 Combi wrench, P/N 0704040

Standard tools

When servicing the SuperSaw 550S grapple saw, the following wrenches and allen keys are required but not supplied with the unit.

Wrenches

- 8 mm
- 10 mm
- 18 mm
- 24 mm
- 30 mm

Allen keys

- 4 mm
- 5 mm
- 6 mm
- 8 mm
- 10 mm
- 14 mm
- 17 mm

Hydraulic Diagram SuperSaw 550S/TL

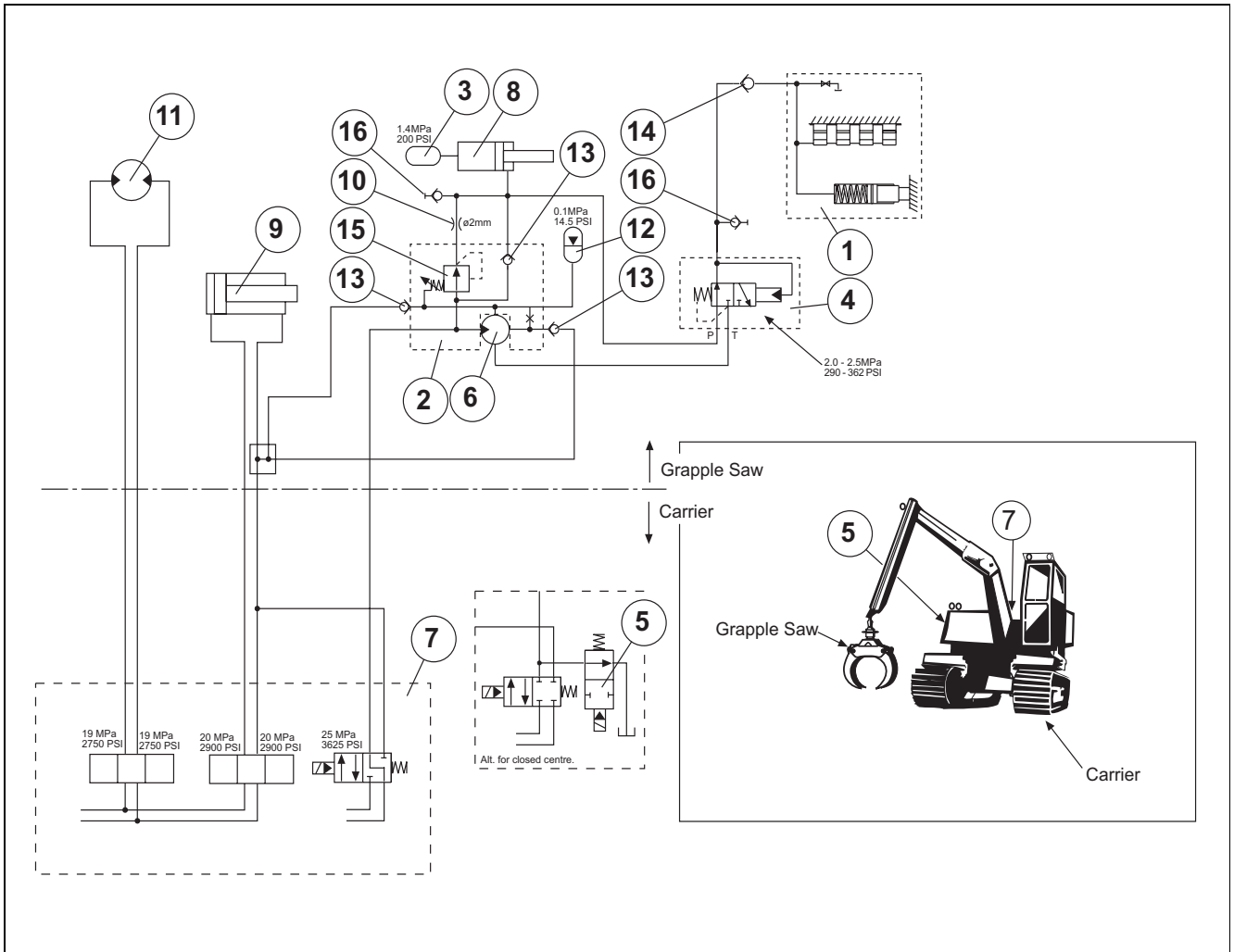

Fig. 10 Hydraulic Diagram SuperSaw 550S / TL

- | | |
|--|--|
| 1. Chain Tension Device | 11. Rotator |
| 2. Saw Motor Manifold | 12. Accumulator for drain circuit |
| 3. Air Tank for saw bar return | 13. Check Valves |
| 4. Pressure Regulating Valve - chain tensioning | 14. Check Valve for chain tensioning |
| 5. Dump Valve * | 15. Pressure Regulating Valve - saw bar feed out |
| 6. Saw Motor | 16. Pressure Test Point |
| 7. Main Valve for Rotator, Grapple and Saw/Tilt* | |
| 8. Feed Out Cylinder | |
| 9. Grapple Cylinder | |
| 10. Restrictor | |

* Required on carrier, but not supplied with the grapple saw.

Hydraulic Diagram SuperSaw 550S/SG

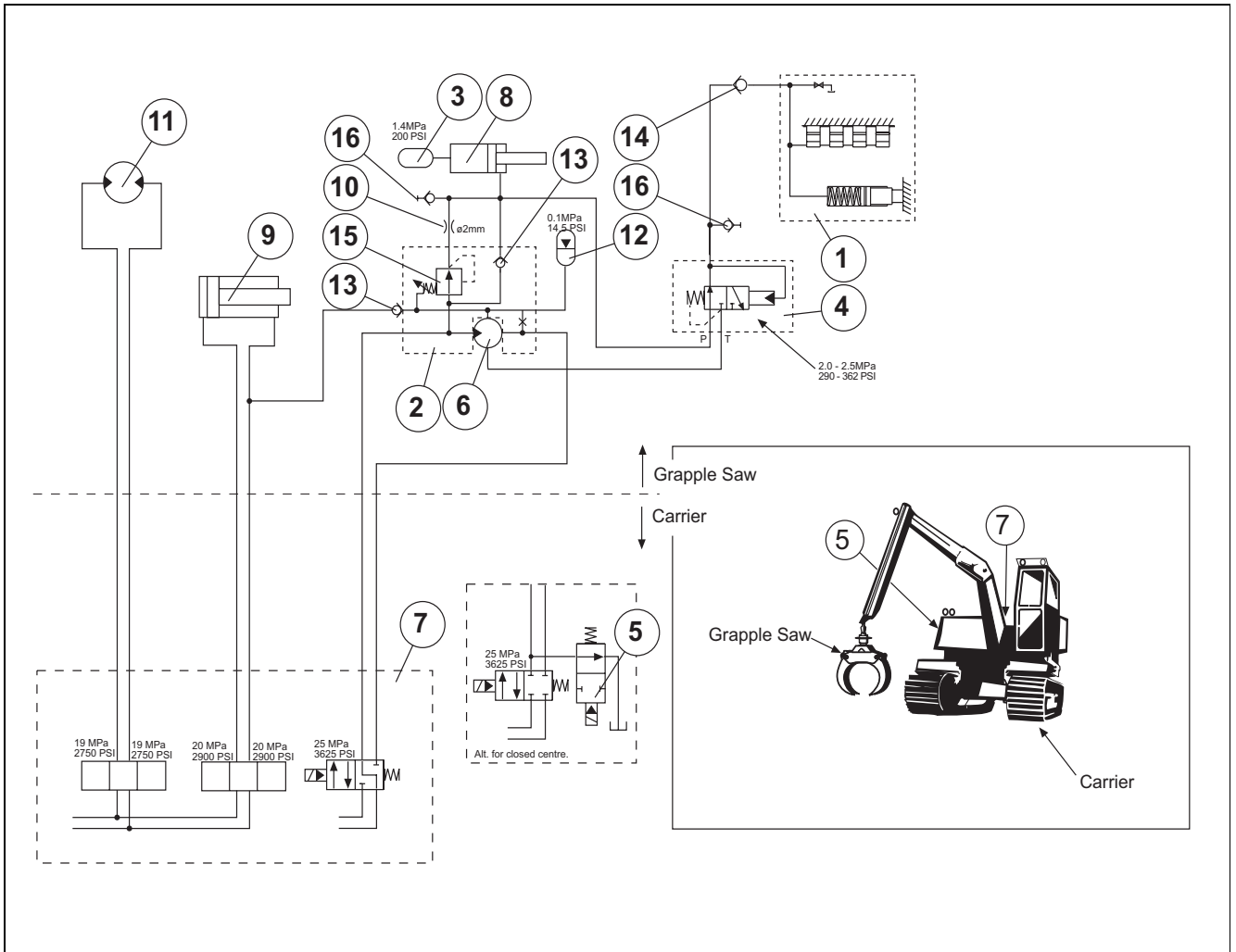

Fig. 11 Hydraulic Diagram SuperSaw 550S / SG

- | | |
|--|--|
| 1. Chain Tension Device | 11. Rotator |
| 2. Saw Motor Manifold | 12. Accumulator for drain circuit |
| 3. Air Tank for saw bar return | 13. Check Valves |
| 4. Pressure Regulating Valve - chain tensioning | 14. Check Valve for chain tensioning |
| 5. Dump Valve * | 15. Pressure Regulating Valve - saw bar feed out |
| 6. Saw Motor | 16. Pressure Test Point |
| 7. Main Valve for Rotator, Grapple and Saw/Tilt* | |
| 8. Feed Out Cylinder | |
| 9. Grapple Cylinder | |
| 10. Restrictor | |

* Required on carrier, but not supplied with the grapple saw.

Functional description

Saw activated chain tensioning

When the feed line (P) is pressurised from the saw function, a reduced pressure (2.0-2.5 MPa/290-360 PSI) from the pressure regulating valve (3) acts on the pistons (1) and (2). The piston (1) keeps the chain tight while the pistons (2) hold the bar holder to the tensioning device when sawing is in process. The spring (4) delivers auxiliary tension during the first sawing operation after replacing the chain. The check valve (5) prevents the chain from becoming slack from external obstructions e.g. undergrowth

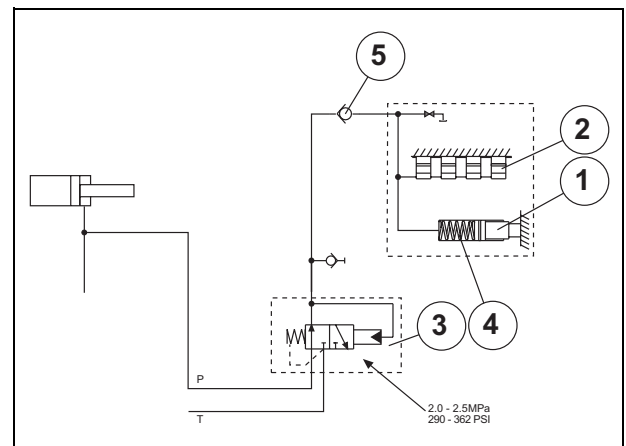

Fig. 12 Saw activated tensioning

- 1 Piston
- 2 Piston
- 3 Pressure regulating valve
- 4 Spring
- 5 Check valve

Functional description

Pressure line feed out system

When the saw motor feed line(2) is pressurised, a reduced pressure / flow will be created in the pressure regulating valve(6) and restrictor(5). See Fig. 13.

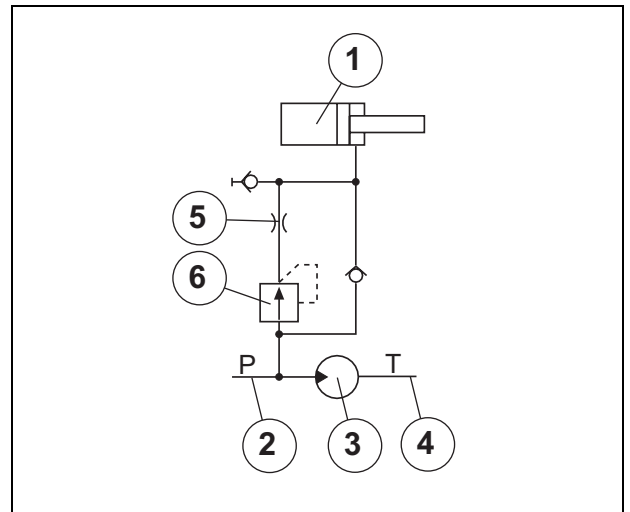

Fig. 13 Pressure line feed out system

- 1 Feed out cylinder
- 2 Saw motor pressure line
- 3 Saw motor
- 4 Saw motor return line
- 5 Restrictor for feed out speed
- 6 Pressure regulating valve for feed out pressure

Functional description

Lubrication system

SuperCut 0703853/0703860 is equipped with the lubrication pump model M06(1), which supplies oil via a cam operation to the saw chain during the entire sawing process. The lubrication pump(1), which delivers a maximum of 6 ml oil volume, is a piston pump that is fed with chain oil from the lubrication oil tank(2), through the intake (3) and delivers it to the saw chain through a check valve (4) when the piston(5) is depressed by the cam curve(6). The supply of oil is proportional, which means that the volume of oil supplied depends on how much the piston(5) is depressed. By using different cams(6), the volume of oil and when it is supplied can be varied up to the maximum of 6 ml.

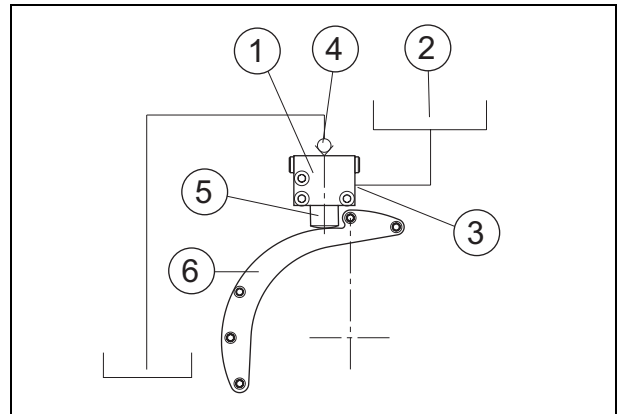

Fig. 14 Lubrication system

1. Lubrication pump M06
2. Lubrication oil tank
3. Oil inlet
4. Check valve
5. Piston
6. Cam curve

Assembly and Disassembly

⚠ Important!

All service and repairs should be carried out by qualified personnel or an authorized repair shop with suitable tools and lifting devices.

Installing the SuperSaw 550S on TL grapples

⚠ Important!

All service and repairs should be carried out by qualified personnel or an authorized repair shop with suitable tools and lifting devices.

⚠ Warning!

The attachment has sharp edges. Use proper wrenches and protective gloves when working on the attachment.

1. Make sure that the operating pressure and flow on the machine for the saw function do not exceed the maximum specified in *Technical data*.
2. Connect the hydraulic hoses for the grapple saw to the rotator. *See Fig. 15.*
 - 1 Connect the hydraulic hose for saw motor 'T' to the manifold for the 'grapple open' function.
 - 2 Connect the hydraulic hose for saw motor case drain to the manifold for the 'grapple open' function.
 - 3 Connect the hydraulic hose for saw motor 'P' to the manifold under the rotator.

Note! The SuperSaw 550S should be installed with the saw motor on the same side as the male grapple arm, therefore make sure that the hoses are connected on the corresponding side of the rotator.

3. Assemble the grapple bracket to the SuperSaw 550S. *See Fig. 16.*
 - 1 Place the dowel pins on the bracket in the upper holes in the saw frame.
 - 2 Tighten the fasteners. For a proper torque *See Technical data.*

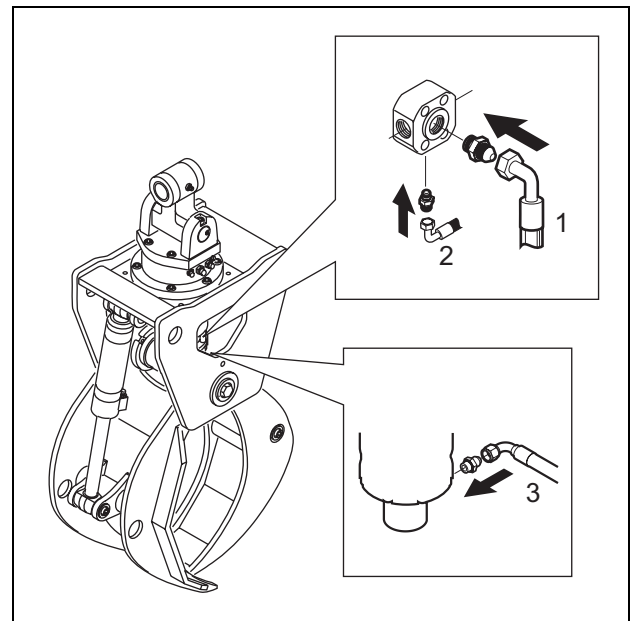

Fig. 15 Connect the hydraulic hoses to the rotator

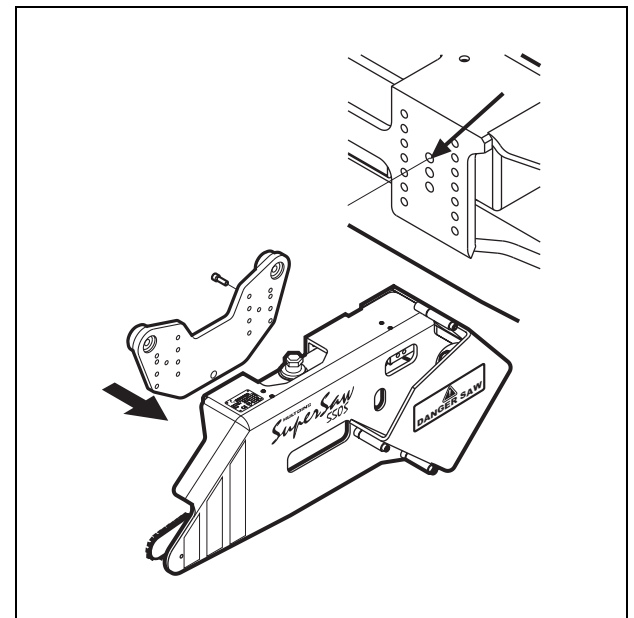

Fig. 16 Assemble the grapple bracket to the SuperSaw 550S

4. Assemble the SuperSaw 550S with the grapple bracket to the grapple frame. *See Fig. 17.*
 - 1 Place the grapple bracket onto the grapple frame.

Note! Make sure to place the saw motor on the same side as the male grapple arm.

 - 2 Place the washers on the back side of the grapple frame and tighten the fasteners. For a proper torque *See Technical data.*

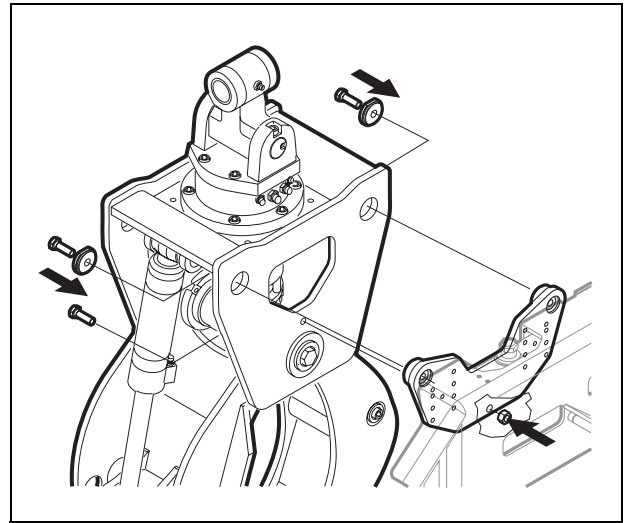

Fig. 17 Assemble the SuperSaw 550S with the grapple bracket to the grapple frame

5. Assemble the hydraulic hoses to the saw motor manifold. *See Fig. 18.*
 - 1 Install a check valve and a bonded seal to the return (T) line of the saw motor.
 - 2 Connect the hose for the saw motor pressure line to the connection marked 'P'.
 - 3 Connect the hose for the saw motor return line to the connection marked 'T'.
 - 4 Connect the hose for the saw motor case drain to the motor manifold.

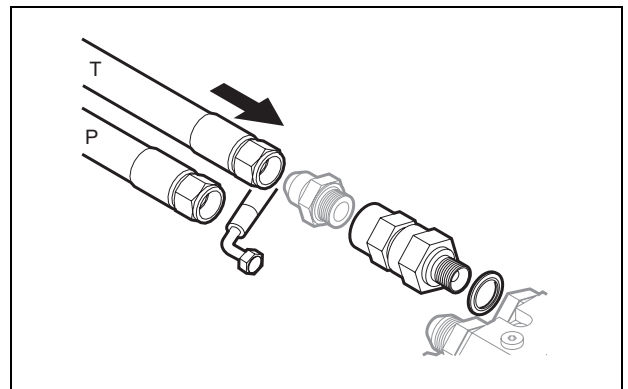

Fig. 18 Assemble the hydraulic hoses to the saw motor manifold

6. Assemble the hydraulic hose for the saw function from the main valve to the rotator. *See Fig. 19.*
7. Start the machine and cautiously operate all functions to ensure everything is operating normally.
8. Test the performance of the grapple saw by making a couple of cuts in the type of wood that the grapple saw is being used for. If either the cutting capacity seems low or the saw bar stalls in the cut, the feed out pressure needs to be adjusted. *See Adjusting saw bar feed out pressure.*

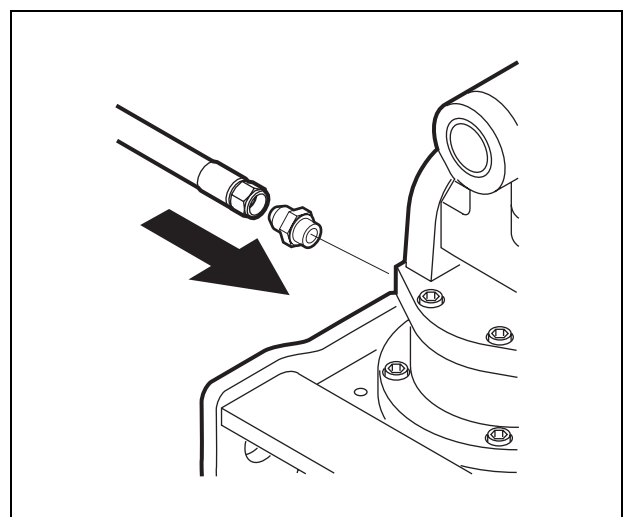

Fig. 19 Assemble the hydraulic hose for the saw function from the main valve to the rotator

Installing the SuperSaw 550S on SG grapples

⚠ Important!

All service and repairs should be carried out by qualified personnel or an authorized repair shop with suitable tools and lifting devices.

⚠ Warning!

The attachment has sharp edges. Use proper wrenches and protective gloves when working on the attachment.

1. Make sure that the operating pressure and flow on the machine for the saw function do not exceed the maximum specified in *Technical data*.
2. Remove the rotor. *See Fig. 20*.

3. Assemble the rotator bracket to the grapple. *See Fig. 21*.
 - 1 Place the rotator bracket onto the grapple, make sure that the dowel pins on the bracket fits in the holes in the grapple frame.

Note! The SuperSaw 550S should be installed with the saw motor on the same side as the male grapple arm.

 - 2 Tighten the fasteners. For a proper torque *See Technical data*.

4. Assemble the hydraulic adaptors for the grapple saw to the rotator. *See Fig. 22*.

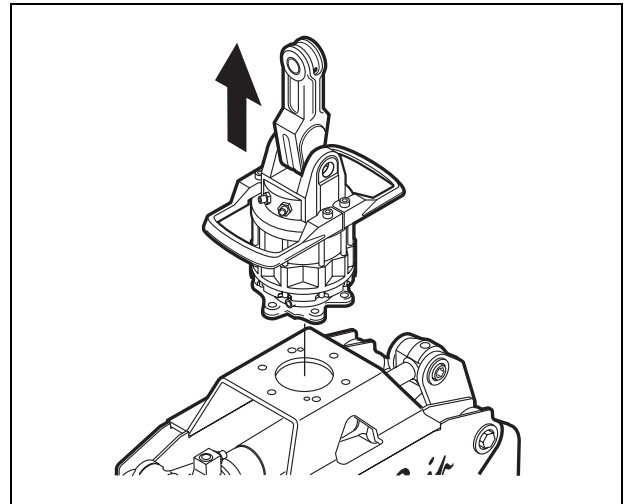

Fig. 20 Remove the rotor

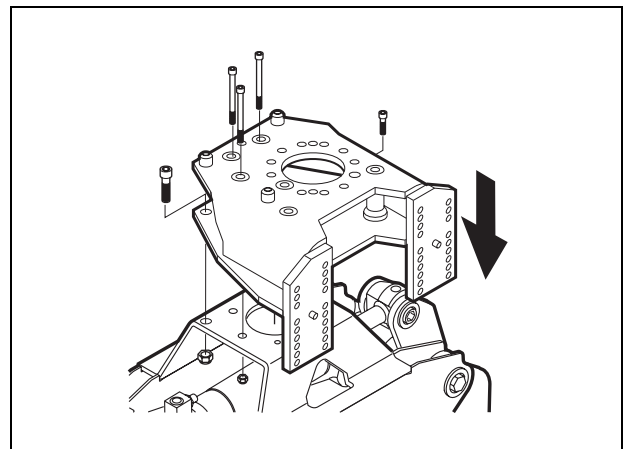

Fig. 21 Assemble the rotator bracket to the grapple

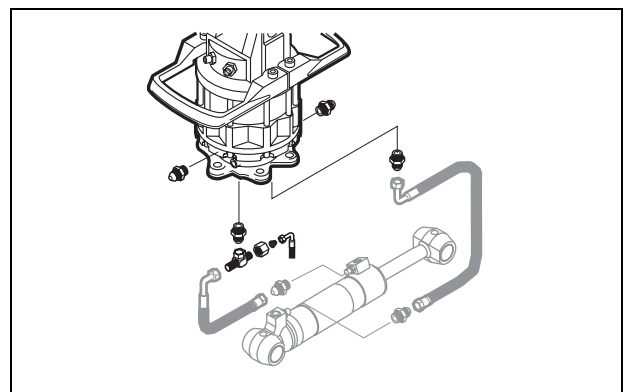

Fig. 22 Assemble the hydraulic adaptors to the rotator

5. Assemble the rotator to the rotator bracket

See Fig. 23.

- 1 Place to rotator onto the rotator bracket. Make sure that the dowel pins on the rotator fits in the holes in the bracket.
- 2 Tighten the fasteners. For a proper torque See *Technical data*.

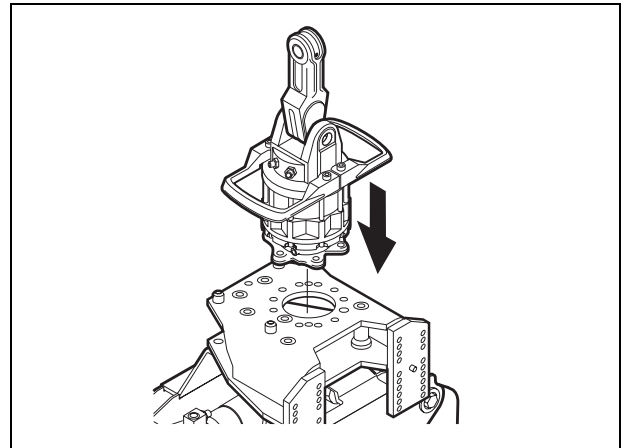

Fig. 23 Assemble the rotator to the rotator bracket

6. Connect the hydraulic hoses for the grapple saw to the rotator. See Fig. 24.

- 1 Connect the hydraulic hose for saw motor 'P' to the rotator port marked '1'.
- 2 Connect the hydraulic hose for saw motor 'T' to the rotator port marked '2'.
- 3 Connect the hydraulic hose for saw motor case drain to the T-fitting at the 'grapple open' function.

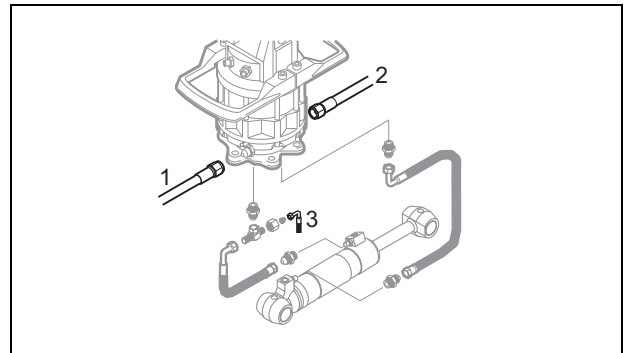

Fig. 24 Connect the hydraulic hoses for the grapple saw to the rotator

7. Assemble the SuperSaw 550S to the rotator bracket.

See Fig. 25.

- 1 Place the dowel pins on the bracket in the upper holes in the saw frame.
- 2 Tighten the fasteners. For a proper torque See *Technical data*.

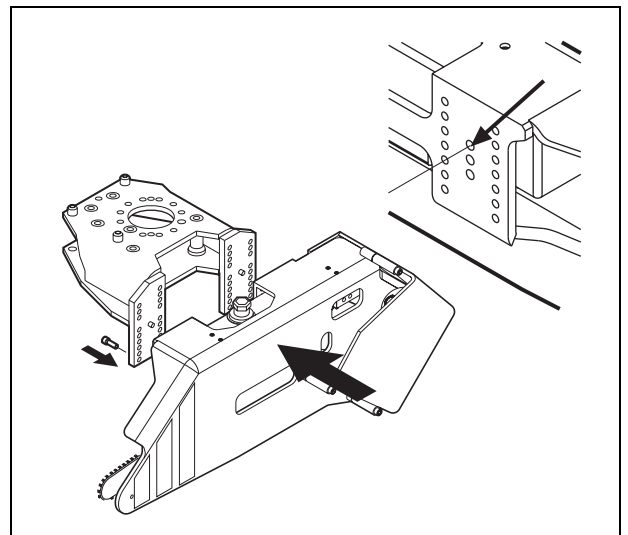

Fig. 25 Assemble the SuperSaw 550S to the rotator bracket

ASSEMBLY AND DISASSEMBLY

8. Assemble the hydraulic hoses to the saw motor manifold. *See Fig. 26.*
 - 1 Connect the hose for the saw motor pressure line to the connection marked 'P'.
 - 2 Connect the hose for the saw motor return line to the connection marked 'T'
 - 3 Connect the hose for the saw motor case drain to the motor manifold.

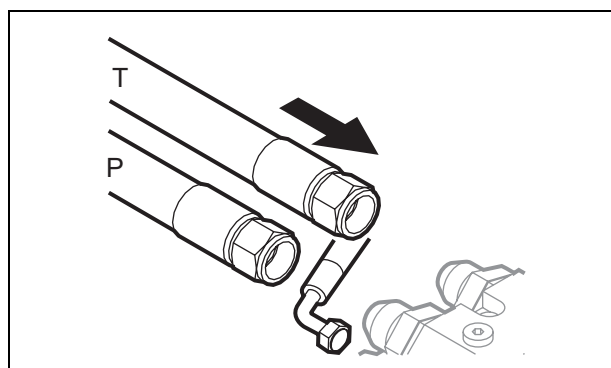

Fig. 26 Assemble the hydraulic hoses to the saw motor manifold

9. Assemble the hydraulic hose for the saw function from the main valve to the rotator.
10. Start the machine and cautiously operate all functions to ensure everything is operating normally.
11. Test the performance of the grapple saw by making a couple of cuts in the type of wood that the grapple saw is being used for. If either the cutting capacity seems low or the saw bar stalls in the cut, the feed out pressure needs to be adjusted. *See Adjusting saw bar feed out pressure.*

Adjusting chain tension pressure

1. Shut down the machine or the power source.
2. Remove the cover over the saw motor.
3. Connect a suitable pressure gauge to the pressure regulating valve. *See Fig. 27.*

⚠ Important!

Never adjust any hydraulic pressures without using a pressure gauge.

4. Place the pressure gauge so that the pressure easily can be checked from the operator's cabin when the saw function is activated
5. Start the machine and activate the saw function for at most 5 seconds at the time.

⚠ Warning!

When operating this equipment ensure all other personnel remain at least 300 feet clear of the machine. Turn the machine off immediately if anyone enters this safety zone.

6. Read the feed out pressure on the pressure gauge while the saw function is activated.

For a proper pressure range, *See Technical data*

7. If necessary, shut down the machine and adjust the tension pressure at the set screw on the pressure regulating valve. *See Fig. 28.*
 - Increase the pressure by tightening the set screw.
 - Decrease the pressure by loosening the set screw.

8. Remove the pressure gauge and assemble the cover over the saw motor.

⚠ Warning!

Never touch or stand close to the pressurized cylinders and hydraulic hoses.

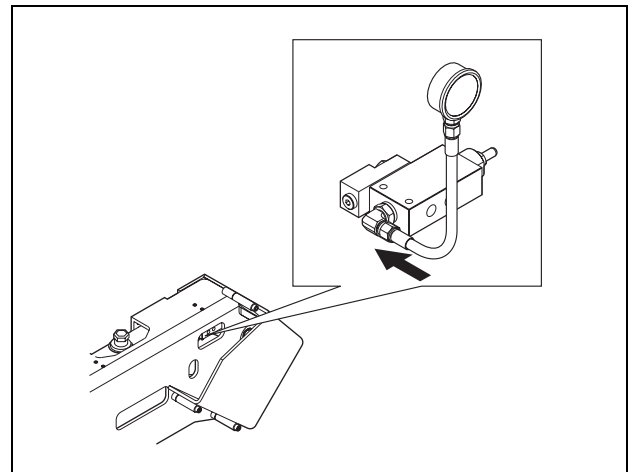

Fig. 27 Connect a pressure gauge to the pressure regulating valve

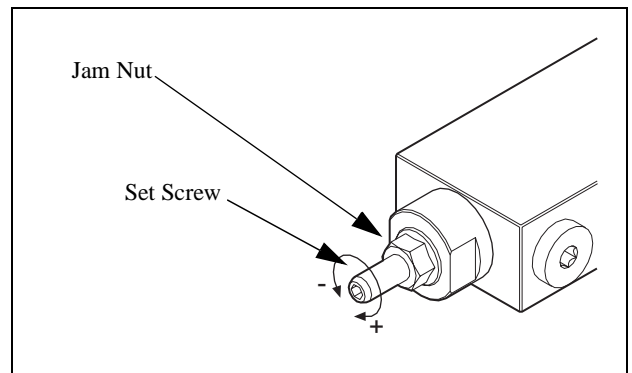

Fig. 28 Adjust the tension pressure

Adjusting saw bar feed out pressure

1. Shut down the machine or the power source.
2. Remove the cover over the saw motor.
3. Connect a suitable pressure gauge to the pressure test point on the feed out cylinder. *See Fig. 27.*

⚠ Important!

Never adjust any hydraulic pressures without using a pressure gauge.

4. Place the pressure gauge so that the pressure easily can be checked from the operator's cabin when the saw function is activated
5. Start the machine and activate the saw function for at most 5 seconds.

⚠ Warning!

When operating this equipment ensure all other personnel remain at least 300 feet clear of the machine. Turn the machine off immediately if anyone enters this safety zone.

6. Read the feed out pressure on the pressure gauge when the saw bar is completely fed out.
For a proper pressure range, *See Technical data*
7. If necessary, shut down the machine and adjust the tension pressure at the set screw on the pressure regulating valve located in the saw motor manifold. *See Fig. 29.*
 - Increase the pressure by tightening the set screw.
 - Decrease the pressure by loosening the set screw.
8. Remove the pressure gauge and assemble the cover over the saw motor.

⚠ Warning!

Never touch or stand close to the pressurized cylinders and hydraulic hoses.

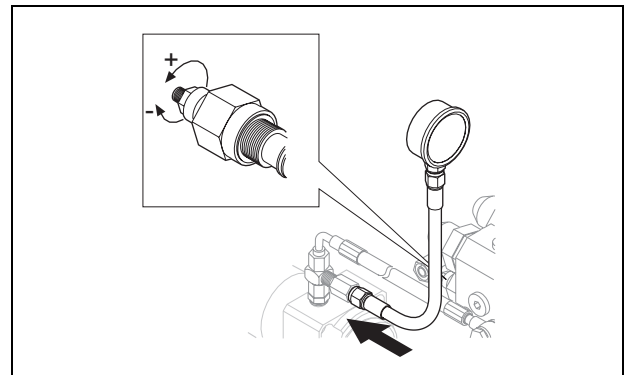

Fig. 29 Adjust the feed out pressure

Adjusting saw bar retraction

Air pressure from the air tank retracts the saw bar automatically when the saw function is released. The saw bar should retract in approx. 1.5 seconds from the full out position. If the retraction speed is too slow or too fast, check the air pressure. The air pressure should be 175 to 200 psi (1.2 - 1.4MPa). *See Fig. 30.*

- If the pressure in the air tank is increased, a faster saw bar retraction will be achieved.
- If the pressure in the air tank is decreased, a slower saw bar retraction will be achieved.

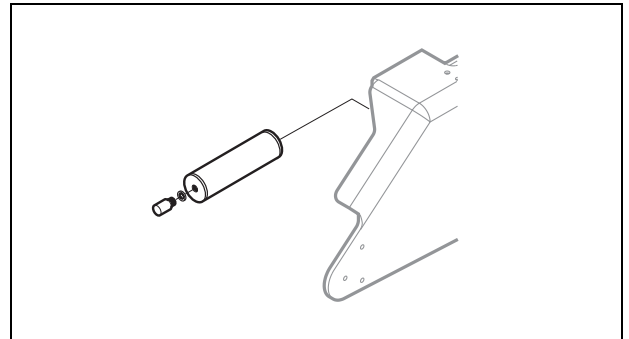

Fig. 30 Air tank

Charging the air tank

When charging the air tank, do as described below.

1. Remove the cap that covers the air nipple.

See Fig. 31.

Use a wrench size 32mm.

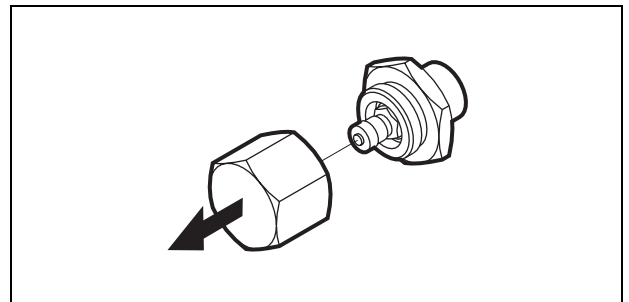

Fig. 31 Remove the big cap

2. Remove the small cap from the air nipple.

See Fig. 32.

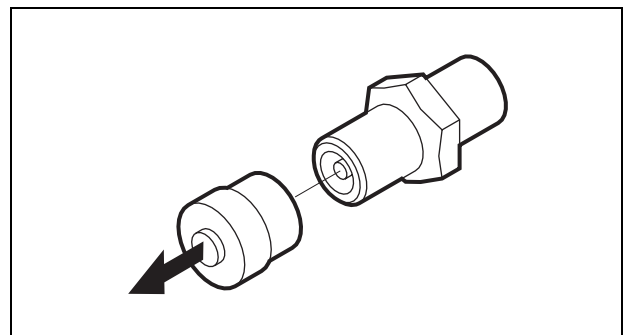

Fig. 32 Remove the small cap

3. Connect the air pump supplied with the grapple saw to the air tank and charge to the required pressure range. *See Fig. 33.*

Use the pressure gauge on the air pump to indicate the air pressure in the air tank.

For proper pressure *See Technical data.*

4. Remove the air pump.
5. Reassemble both the small and the big cap to the air nipple to protect the air tank from dust and external forces.

Note! It is very important that both caps is reassembled to the nipple, otherwise problems with dirt in the air tank may occur.

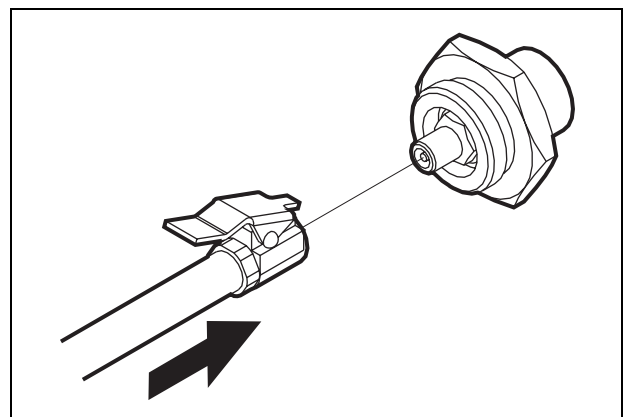

Fig. 33 Connect the air pump to the nipple

Depressurizing the air tank

When depressurizing the air tank, do as described below.

1. Remove the cap that covers the air nipple.

See Fig. 34.

Use a wrench size 32mm.

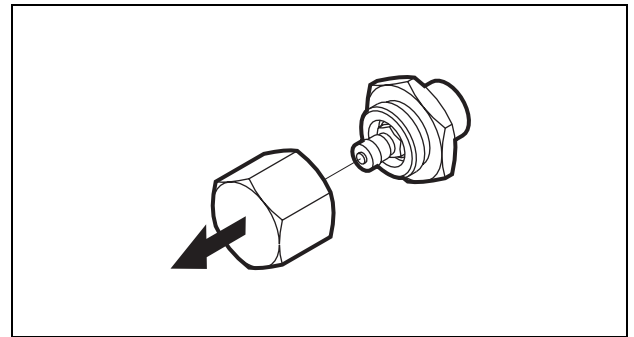

Fig. 34 Remove the big cap

2. Remove the small cap from the air nipple.

See Fig. 35.

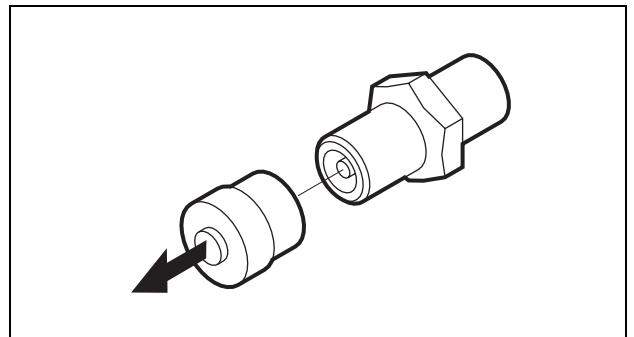

Fig. 35 Remove the small cap

3. Push the small pin in the center of the air nipple to evacuate the air pressure. *See Fig. 36.*

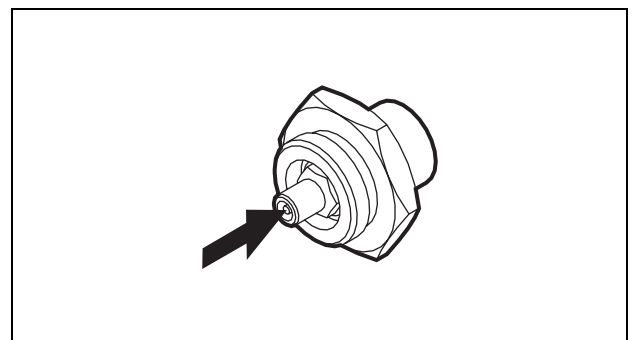

Fig. 36 Push the pin

4. Reassemble both the small and the big cap to the air nipple to protect the air tank from dust and external forces.

Note! It is very important that both caps is reassembled to the nipple, otherwise problems with dirt in the air tank may occur.

Replacing Accumulator

The accumulator is located under the saw motor cover.

See Fig. 37.

The purpose of the accumulator is to ensure a low pressure in the drain circuit for the saw motor and for the pressure regulating valve.

When replacing the accumulator, do as described below.

⚠ Important!

All service and repairs should be carried out by qualified personnel or an authorized repair shop with suitable tools and lifting devices.

⚠ Warning!

The attachment has sharp edges. Use proper wrenches and protective gloves when working on the attachment.

1. Close the grapple completely.
2. Place the grapple securely on the ground.
3. Shut down the machine or the power source.
4. Disassemble the hose and the nipples from the accumulator. See Fig. 38.

Note! Consider the environment. Plug all connections to avoid unnecessary spill of oil.

5. Remove the accumulator from the accumulator bracket. See Fig. 39.

6. Install a new accumulator with the correct gas pressure.
For a proper gas pressure, See *Technical data*
7. Reassemble the nipple and the hose to the accumulator.

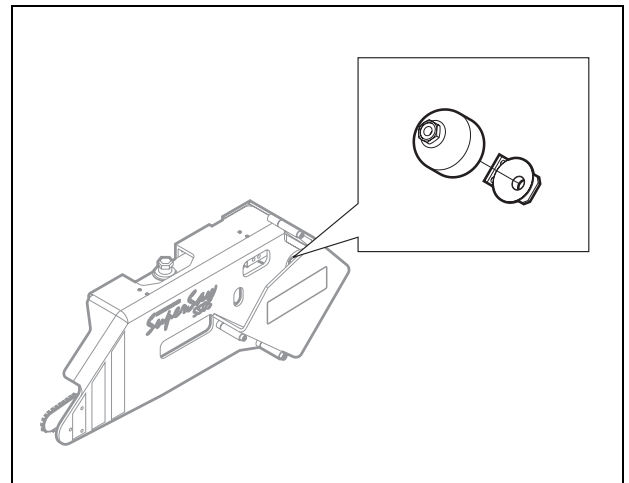

Fig. 37 Accumulator location

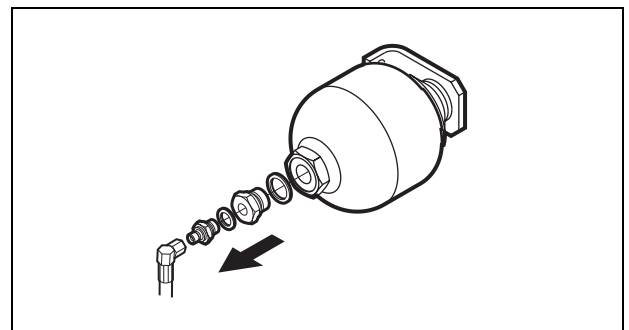

Fig. 38 Remove the hose and nipples from the accumulator

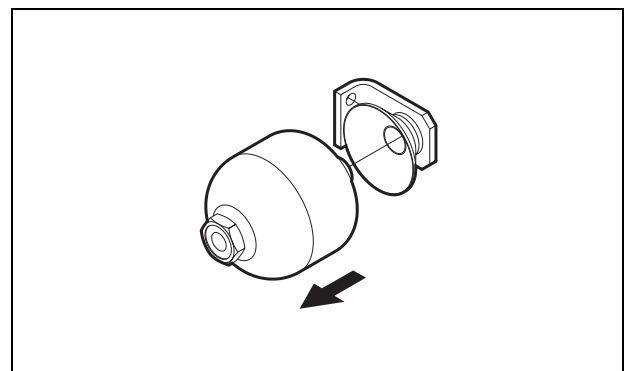

Fig. 39 Remove the accumulator

Refilling lubrication oil tank

 **Warning!**

The attachment has sharp edges. Use proper wrenches and protective gloves when working on the attachment.

1. Close the grapple completely.
2. Place the grapple securely on the ground.
3. Shut down the machine or the power source.
4. Carefully clean the area around the filler cap to avoid dirt getting into the oil tank.
5. Open the filler cap.
6. Check if the strainer in the filler cap is damaged or missing, replace if necessary.

Note! Never refill the tank with the strainer damaged or missing.

7. Refill the oil tank.

Note! Never put used oil, hydraulic fluid or old motor oil in the saw chain lubrication system. Always use a high quality saw chain/bar lubricant with Hultdins SuperSaw/SuperCut products.

8. Close the filler cap.

Assembly and disassembly

Bleeding chain tension system

Saw activated tensioning

1. Make sure that the unit is resting securely on the ground.
2. Tip the unit backwards as far as possible so that the bleeder valve (1) is as high as possible in relation to the tension pistons.
3. Remove the saw chain. *See Replacing saw chain.*



Important!

When working on the saw chain always ensure the engine is shut off and wear safety gloves to prevent injuries. Remove the saw chain when making any adjustments or servicing the saw unit.

4. Open the bleeder valve (1) 1- 2 turns.
Use the tool P/N 0704040, (3) *See Fig. 40.*
5. Start the machine and run the sawing operation several times until the oil coming from the bleeder valve is free from air.
6. Close the bleeder valve (1). As there is no saw chain installed, the piston for the tensioning will move to the outer position and stay there. Repeat this process after about 30 minutes of operation.
7. Install the saw chain. *See Replacing saw chain*



Important!

When working on the saw chain always ensure the engine is shut off and wear safety gloves to prevent injuries. Remove the saw chain when making any adjustments or servicing the saw unit.

Note! Always bleed the system if there is any suspicion of air having entered the system, e.g. after replacing a hose or other components

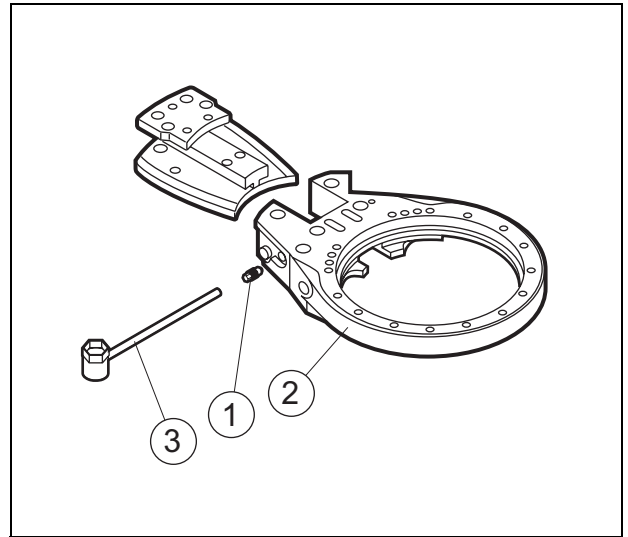

Fig. 40 Bleeding chain tension system

Bleeding chain tension system

Constant pressure activated tensioning

1. Remove the saw chain. *See Replacing saw chain*

⚠ Important!

When working on the saw chain always ensure the engine is shut off and wear safety gloves to prevent injuries. Remove the saw chain when making any adjustments or servicing the saw unit.

2. Start the machine and let it idle. As there is no saw chain installed, the piston for the tensioning will move to the outer position and stay there.
3. Make sure that the unit is resting securely on the ground.
4. Tip the unit backwards as far as possible so that the bleeder valve (1) is as high as possible in relation to the tension pistons.
5. Open the bleeder valve (1) 1- 2 turns.
Use the tool P/N 0704040, (3) *See Fig. 41.*
6. Close the bleeder valve(1) when the oil appearing from the valve is clear from air. Repeat this process after about 30 minutes of operation.
7. Install the saw chain. *See Replacing saw chain*

⚠ Important!

When working on the saw chain always ensure the engine is shut off and wear safety gloves to prevent injuries. Remove the saw chain when making any adjustments or servicing the saw unit.

Note! Always bleed the system if there is any suspicion of air having entered the system, e.g. after replacing a hose or other components

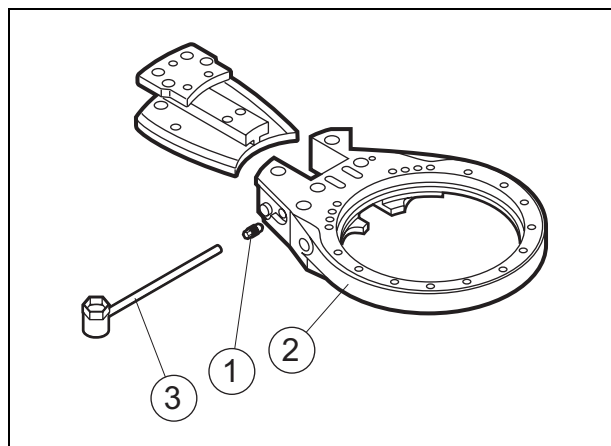

Fig. 41 Bleeding chain tension system

Bleeding chain lubrication system

When bleeding the chain lubrication system, do as described below.

1. Open the filler cap on the lubrication oil tank.
2. Remove the plug on the lubrication oil pump. *See Fig. 42.*
3. Wait until chain oil covers the entire hole in the pump and then reinstall the plug.
4. Close the filler cap.

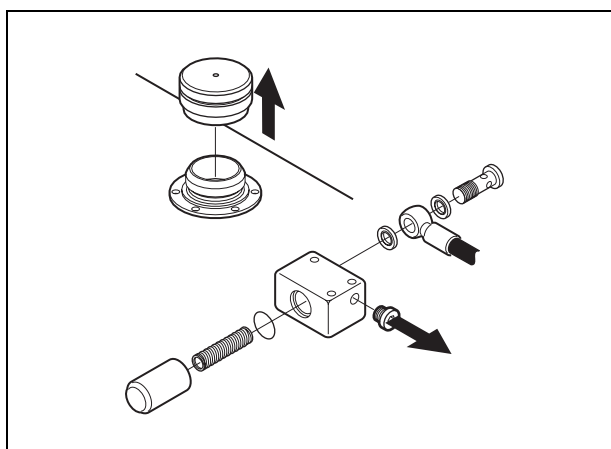

Fig. 42 Bleeding chain lubrication system

Replacing saw chain

The first signs of a worn chain are abnormally long saw times and blue smoke emerging from the cut. When changing the saw chain we recommend the following method.

Warning!

Before performing any maintenance or service work, lower the attachment to the ground and shut off the engine. Turn off any master shut-offs and do not allow personnel in the cab.

Important!

When working on the saw chain always ensure the engine is shut off and wear safety gloves to prevent injuries. Remove the saw chain when making any adjustments or servicing the saw unit.

1. Place the unit steady on the ground with the SuperCut unit facing up.(Where possible)
2. Depressurise the automatic chain tensioner by loosening the bleed screw (1) approx. 1 turn. Apply the tool (2) on the front guide screw (3) and push the holder (4) backwards. *See Fig. 43.*
3. Press in the mechanical locking device (5).
4. Tighten the bleed screw (1).
This is to prevent air from being drawn into the system when the spring (7) acts on the tensioning piston (6).
5. Remove the saw chain.
6. Install new saw chain and slowly pull out the saw chain by hand until the mechanical locking device disengages.
7. Operate the saw carefully a few times to secure the pressure in the chain tensioner. If after replacing a chain it repeatedly jumps off the saw bar, you may have to bleed the system.

See Bleeding chain tension system

8. Problems to replace the saw chain can appear depending on saw dust or other debris in the slots (8). The movement of the holder (4) can be limited due to debris and if so the holder must be disassembled and cleaned.

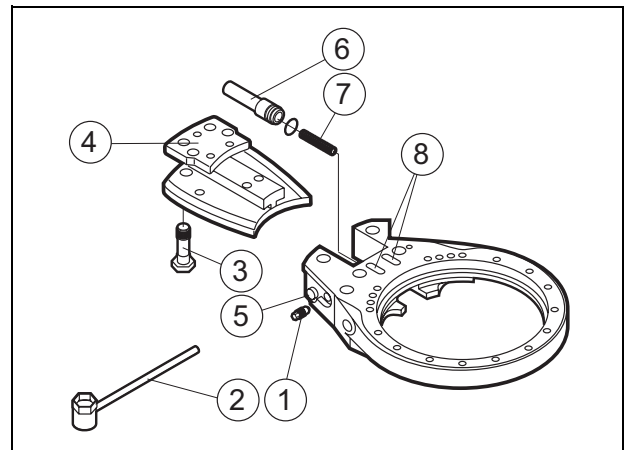

Fig. 43 Replacing saw chain

Replacing saw bar

Warning!

Before performing any maintenance or service work, lower the attachment to the ground and shut off the engine. Turn off any master shut-offs and do not allow personnel in the cab.

Important!

When working on the saw chain always ensure the engine is shut off and wear safety gloves to prevent injuries. Remove the saw chain when making any adjustments or servicing the saw unit.

1. Place the unit steady on the ground with the SuperCut unit facing up.(Where possible)
2. Remove the saw chain. *See Replacing saw chain*
3. Loosen off the guide screws (3), $W=16$ mm, and pull out the saw bar. *See Fig. 44.*
4. Replace the saw bar and tighten the guide screws (3).
For Oregon saw bar use guide screw #2, P/N 0704048 and for Sandvik-Windsor use #1, P/N 0704049.
5. Replace saw chain.*See Replacing saw chain*

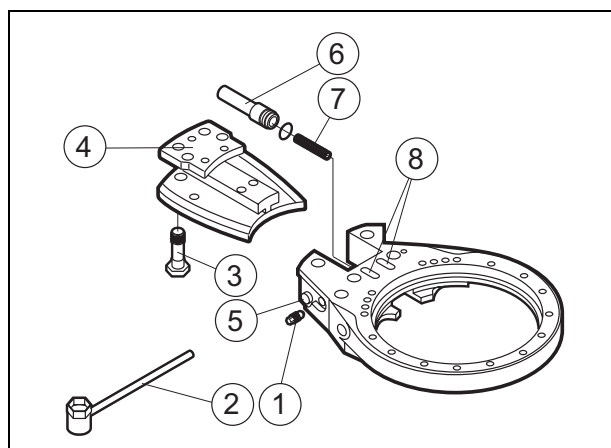

Fig. 44 Replacing saw bar

Replacing bar holder

Warning!

Before performing any maintenance or service work, lower the attachment to the ground and shut off the engine. Turn off any master shut-offs and do not allow personnel in the cab.

Important!

When working on the saw chain always ensure the engine is shut off and wear safety gloves to prevent injuries. Remove the saw chain when making any adjustments or servicing the saw unit.

When replacing the bar holder, do as described below.

1. Stop the machine and rest the unit securely on the ground.
2. Remove the saw chain. *See Replacing saw chain.*
3. Remove the saw bar. *See Replacing saw bar.*
4. Loosen the guide screws (1) with an 11 mm wrench until the bar holder (2) can be removed from the tensioning device (3). *See Fig. 45.*
Note! Never start the machine with the bar holder removed.
5. Inspect and clean the grooves (4). *See Fig. 46.*
6. Save all the parts, screws etc. from the old bar holder to be used with the new one.
7. The stop screw (5), W = 6mm, must never be screwed in further than to the back edge (A) of threaded hole. *See Fig. 47.*
8. Lock the stop screw (5) with the locking device and stop screw (6), W = 4 mm.
9. Tighten the guide screw (8) to the bottom, then tighten the stop screw (7) until it stops on the guide screw (8).
10. Lock the stop screw (7) with stop screw and locking device (9). Stop screw (10) must be tightened and locked with thread sealant at a distance of 1.5 mm (0.06") from the inside edge (B). *See Fig. 47.*
For the right thread sealant, see Technical data.
11. Assemble the bar holder (2) into the tensioning device (3). Position the guide screws (1) into the grooves (4) and tighten.
12. Replace saw bar. *See Replacing saw bar.*
13. Replace saw chain. *See Replacing saw chain.*

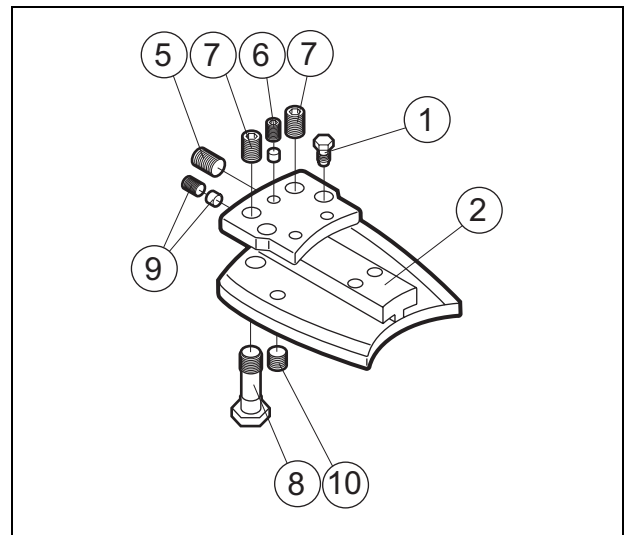

Fig. 45 Bar holder

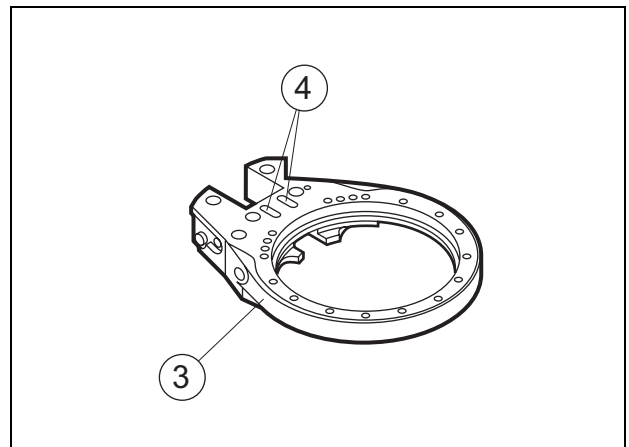

Fig. 46 Tensioning device

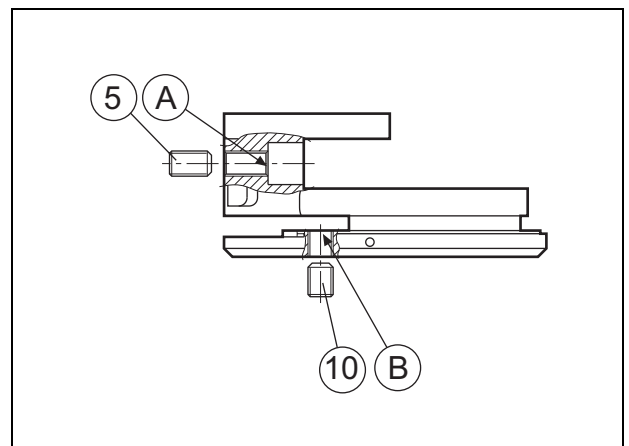

Fig. 47 Stop screws in bar holder

Manual chain tensioning

During malfunction of the automatic chain tension device, the chain can be tensioned manually by doing as described below.

1. If necessary, remove the hydraulic hose for the tensioner (A) and plug all connections. See Fig. 48.

⚠ Important!

Consider the environment. Plug all connections to avoid unnecessary spill of oil.

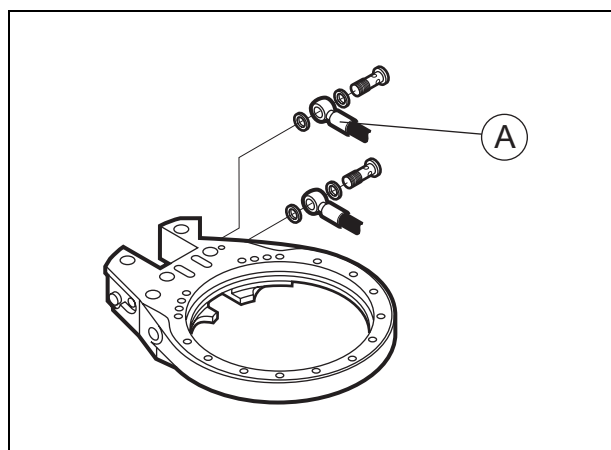

Fig. 48 Hydraulic hose - chain tensioning

2. Loosen the set screw (6), $W = 4$ mm, and replace the 20mm long set screw (5) with a 40 mm long set screw. See Fig. 49.
3. Tighten the set screw (5) until the chain is properly tensioned. See Fig. 49.
4. Tighten the set screw (6). See Fig. 49.
5. Lock the bar holder (2) with the two set screws (10), $W = 6$ mm. See Fig. 49.
6. The saw unit can now be used as normal while awaiting repair or replacement of the failed components.
7. When switching back to the automatic tensioner, the 40mm long set screw has to be replaced with the 20 mm long set screw and the set screws (10) have to be loosened so that the upper end of the screw is approx. 1.5 mm below the surface of the bar holder.

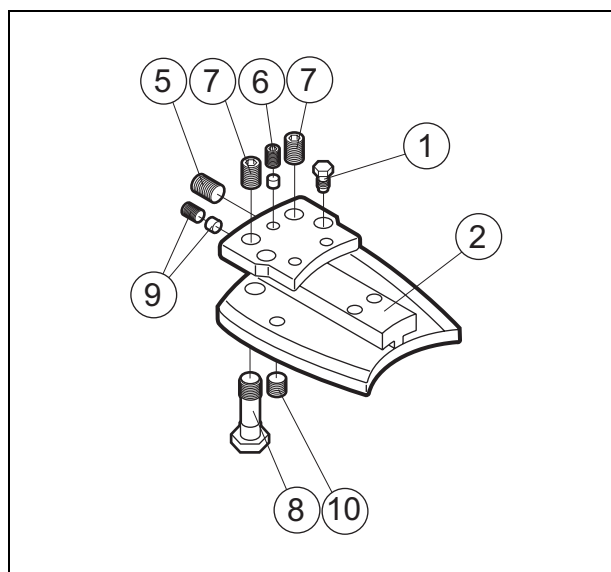

Fig. 49 Bar holder

Replacing broken guide screw

If a saw bar is destroyed, it is possible that the guide screws (8) are damaged. *See Fig. 50.* For example, may only the threaded end remain in the bar holder (2).

When replacing the guide screws, do as described below.

1. Remove the saw chain. *See Replacing saw chain*



Warning!

When working on the saw chain always ensure the engine is shut off and wear safety gloves to prevent injuries. Remove the saw chain when making any adjustments or servicing the saw unit.

2. Remove the saw bar. *See Replacing saw bar*
3. Remove the bar holder. *See Replacing bar holder*
4. Loosen the set screws (9), W=4 mm.
5. Loosen the set screws (7), W=5 mm.
6. The guide screw (8) is equipped with a hex key hole in the threaded end. Use a 5 mm allen key to remove the broken part of the guide screw.
7. Install and tighten the new guide screw by hand until it stops against the bar holder.
8. Loosen the guide screw approx. 1/4 turn.
9. Tighten the set screw (7) until it stops on the guide screw (8).
10. Lock the set screw (7) with the set screw and locking device (9).
11. Assemble the bar holder. *See Replacing bar holder*
12. Install the saw bar. *See Replacing saw bar*
13. Install the saw chain. *See Replacing saw chain*



Warning!

When working on the saw chain always ensure the engine is shut off and wear safety gloves to prevent injuries. Remove the saw chain when making any adjustments or servicing the saw unit.

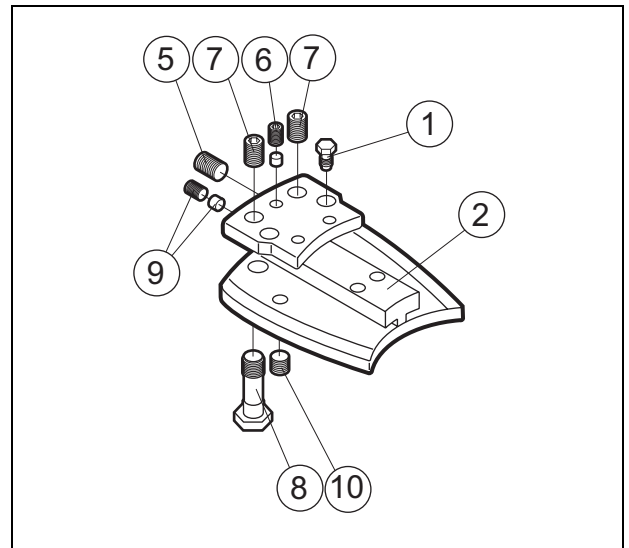

Fig. 50 Bar holder

Replacing piston seals

1. The piston seal (1) is made of two parts. Separate the yellow and brown seals.
2. Apply oil to the piston (3) and the piston seal (1).
3. Assemble the piston seal. *See Fig. 51.*
 - 1 Assemble the “yellow ring“ of the piston seal (1).
 - 2 Assemble the “brown ring“ of the piston seal (1). Avoid stretching the seal too much.
 - 3 Assemble the guide ring (2).
 - 4 Press on the assembly tool (P/N 0703745) to compress the brown seal ring. Let it hold a couple of minutes. The assembly tool can be ordered from Hultdins on P/N 0703745. *See Fig. 52.*
 - 5 Remove the assembly tool (P/N 0703745).
4. Apply oil to the inside of the cylinder tube and press the piston into the cylinder tube.

Note! IF CARE IS TAKEN, THE PISTON SEAL CAN BE ASSEMBLED WITHOUT USING THE TOOL.

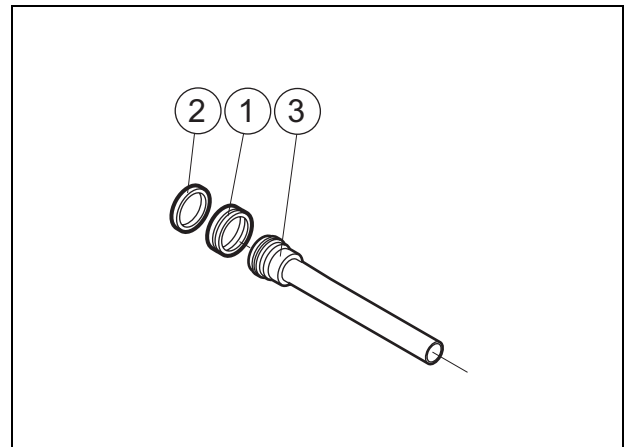

Fig. 51 Piston seals

- 1 Piston seal - P/N 0120007
- 2 Guide ring - P/N 0118534
- 3 Piston - P/N 0703616

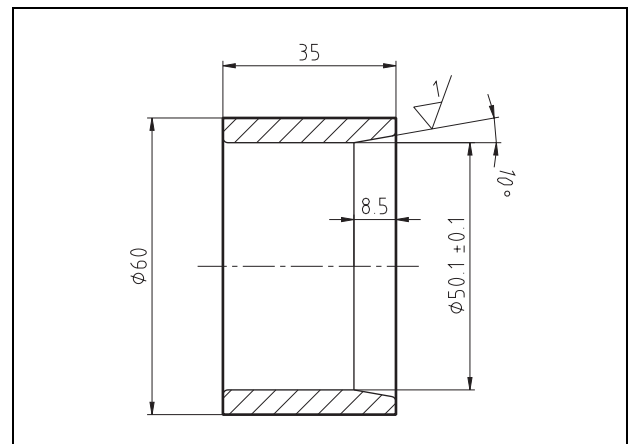

Fig. 52 Assembly tool

Replacing piston rod seal

1. Remove the piston (2) from piston rod (6) by loosening the bolt (1). W=14 mm. *See Fig. 53.*
2. Assemble the piston rod seals. *See Fig. 53.*
 - 1 The piston rod seal (4) is made of two parts. Separate the yellow and brown seals.
 - 2 Compress the "yellow" seal. *See Fig. 54.*
 - 3 Assemble the yellow seal in the head (3) by hand or by using a blunt tool.
 - 4 Assemble the "brown" ring of the piston rod seal. Use a blunt tool eg. shaft on a small screw driver and press all around the ring.
 - 5 Replace the O-ring (5).

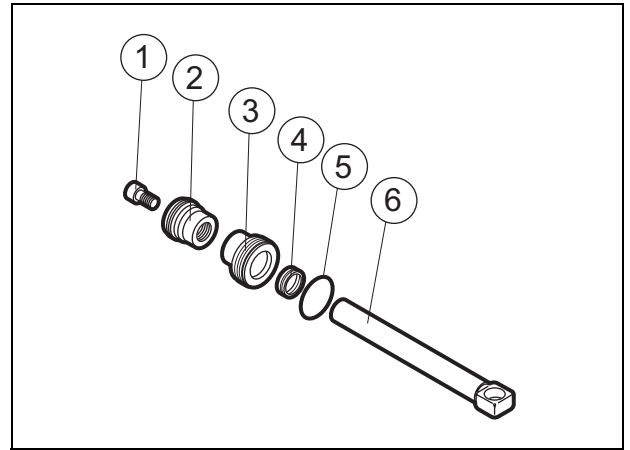

Fig. 53 Piston rod seals

- 1 Bolt
- 2 Piston
- 3 Head
- 4 Piston rod seal
- 5 O-ring
- 6 Piston rod

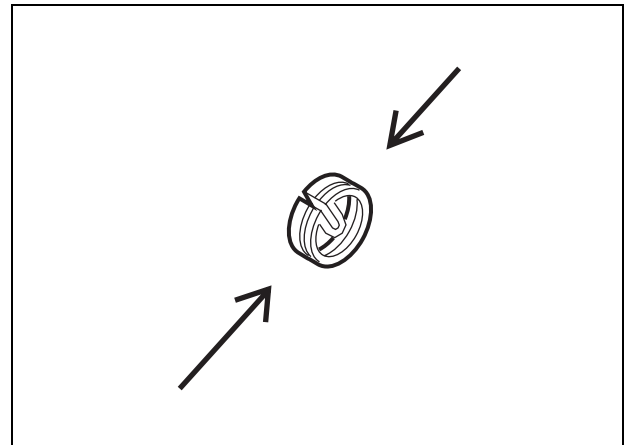

Fig. 54 Compressing piston rod seal

Testing function of check valve

To prevent the chain from jumping off unintentionally if the saw chain is affected by external forces, ie if the saw chain is stuck in under growth when lifting the unit, a check valve (1) is assembled at the inlet port for the chain tensioner. See Fig. 55.

When testing the function of the check valve, do as described below.

1. Remove the saw chain. See *Replacing saw chain*
2. Replace the plug (2) with a pressure gauge ($\frac{1}{4}$ " BSPP Port).
3. Run the saw function for approx. 3 secs.
4. If the pressure falls quickly to 0 - 1.0 MPa (0 -140 PSI) after sawing operation, the check valve is leaking and must be replaced. If the pressure falls slowly, however, e.g. 1.5 MPa (210 PSI) in 30 secs, the valve is functioning properly.
5. Remove the pressure gauge.
6. Install the plug.
7. Install the saw chain. See *Replacing saw chain*

Important!

When working on the saw chain always ensure the engine is shut off and wear safety gloves to prevent injuries. Remove the saw chain when making any adjustments or servicing the saw unit.

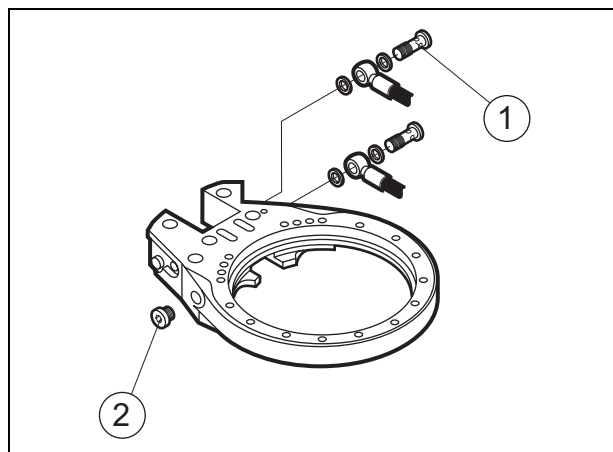

Fig. 55 Check valve for chain tensioning

Replacing tension- and lub. oil hoses

To obtain best hose connection and to avoid unnecessary hose damages the tension hose (2) must be assembled tight towards the flange (3). Also keep the tension hose (2) tight to the recess grooves in the tensioning device and keep the lube oil hose (1) tight to the tension hose. See Fig. 56.

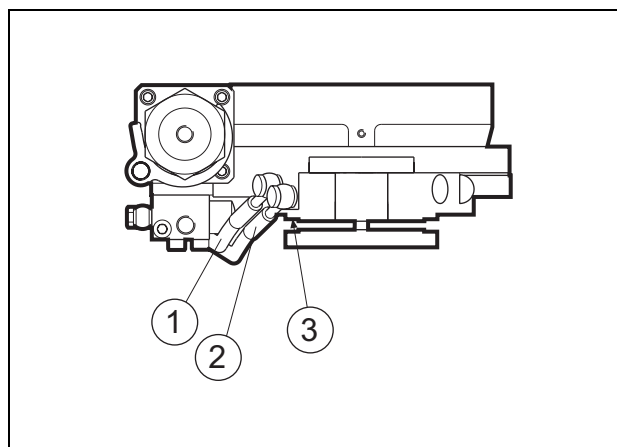

Fig. 56 Replacing hoses

Maintenance instructions

 **Warning!**

Before performing any maintenance or service work, lower the attachment to the ground and shut off the engine. Turn off any master shut-offs and do not allow personnel in the cab.

 **Warning!**

Never touch or stand close to the pressurized cylinders and hydraulic hoses.

 **Warning!**

The attachment has sharp edges. Use proper wrenches and protective gloves when working on the attachment.

Regular maintenance

Daily maintenance

Make sure that:

- Nothing abnormal has happened to the grapple saw regarding fastener joints and hydraulic hoses.
- No damages or cracking have occurred on the grapple saw.
- There is no leakage on the grapple saw.
- At the beginning of each shift, always start with a sharp saw chain!
- At the end of each shift, always park the grapple saw with the grapple completely open.

Tighten any loose items and repair any damages.

Every 250 hours of operation

Make sure that:

- No fasteners are loose.
- The hydraulic hoses are not damaged.
- No damages or cracking have occurred on the grapple saw.
- There is no leakage on the grapple saw

Repair or replace any damaged or worn components.

Every year of operation

Clean the strainer in the filler cap once every year or whenever needed.

Lubrication

The saw unit should be lubricated every 8 to 200 hours of operation depending on the conditions that the unit is working under. The unit has 2 lubrication points as shown here. See Fig. 57.

Note! Use a water free grease with lithium, molybdenum or silicone additive. The abilities of the grease should include excellent water durability and antirust capabilities as well as good adhesive abilities and mechanical stability. NLGI Class 2.

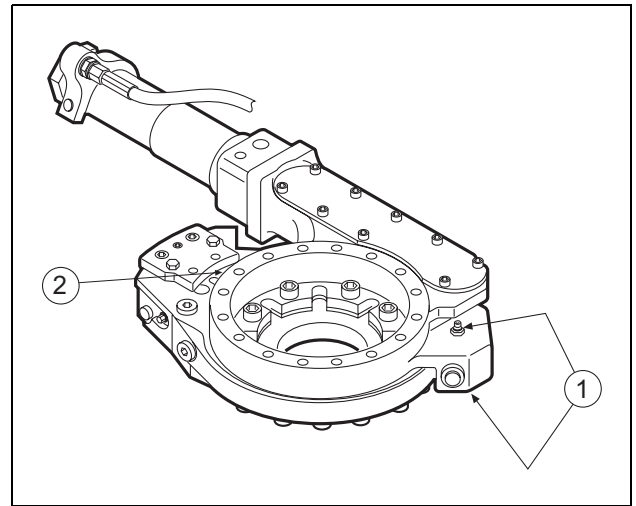

Fig. 57 Lubrication points

1. Stand, 1 pcs.
2. Bearing, 1 pcs.

Fastener joints and hydraulic hoses

Make sure at daily maintenance of the grapple saw that nothing abnormal has occurred with the grapple saw regarding fastener joints and hydraulic hoses.

The first month of operation

Fasteners

Tightening of the all fastners should be made once a week during the first month of operation.

See *Technical data* regarding wrench sizes and torque.

Troubleshooting

⚠ Warning!

Before performing any maintenance or service work, lower the attachment to the ground and shut off the engine. Turn off any master shut-offs and do not allow personnel in the cab.

SuperSaw 550S

Symptom	Probable cause	Action
The saw motor is rotating backwards when the grapple open function is activated.	Check valve in saw motor “T” line is leaking or missing	Clean or replace the check valve
Frequent problems with leaking saw motor shaft seal.	Malfunction of the check valve in the saw motor manifold.	Clean or replace the check valve.
	The inner leakage of the saw motor is too high in comparison with the capacity of the accumulator in the case drain circuit.	Replace the saw motor.
	The accumulator in the saw motor case drain circuit is damaged	Replace the accumulator
Saw bar feed out malfunction	Feed out pressure is too low	Adjust the feed out pressure
	Damaged feed out cylinder seals, which will cause the air tank to fill up with oil.	Drain the air tank from oil and replace the seals.
Lubrication Malfunction (For more information on this issue see Troubleshooting SuperCut)	Membrane in filler cap is damaged	Replace the membrane.
Difficulties to adjust the tension pressure	Accumulator in the saw motor case drain circuit is damaged	Replace the accumulator
	Malfunction of the check valve in the saw motor manifold for the saw bar retraction function.	Clean or replace the check valve

Troubleshooting

Warning!

Before performing any maintenance or service work, lower the attachment to the ground and shut off the engine. Turn off any master shut-offs and do not allow personnel in the cab.

SuperCut

Symptom	Probable cause	Action
Saw bar wears abnormally quick or top roller failure.	Chain tension pressure is too high	Adjust chain tension pressure
	Chain lubrication malfunction	Check lubrication system
Hydraulic hoses wear abnormally.	Sharp edged on equipment.	Grind any sharp edges.
	Hydraulic hoses routing.	Change the routing of the hydraulic hoses so that they are not too close to sharp edges.
Chain jumps off	Chain tension pressure is too low	Adjust chain tension pressure
	Air in the tensioner system	Bleed the tensioner system
	Leaking check valve	Test check valve - clean or replace if necessary
	Hydraulic hoses for tensioner are broken.	Replace the hoses.
Chain lubrication system malfunction	Lubrication oil tank is empty	Refill lubrication oil
	Check valve on lub. oil pump is leaking	Test check valve - clean or replace if necessary
	Air in lubrication system	Bleed system
	Hydraulic hoses for lub. system are broken.	Replace the hoses.

HULTDINS
SuperSaw™



0100-7000031



Hultdin System AB
Skolgatan 12, SE-930 70 MALÅ, Sweden
Tel +46 953 418 00, Fax +46 953 418 01
E-mail: sales@hultdins.se

Hultdins Inc.
P.O. Box 1205, 22 Morton Ave. East
Brantford, Ontario, Canada N3T 5T3
Tel (519) 754-0044, Fax (519) 754-1569
E-mail: info@hultdins.com