

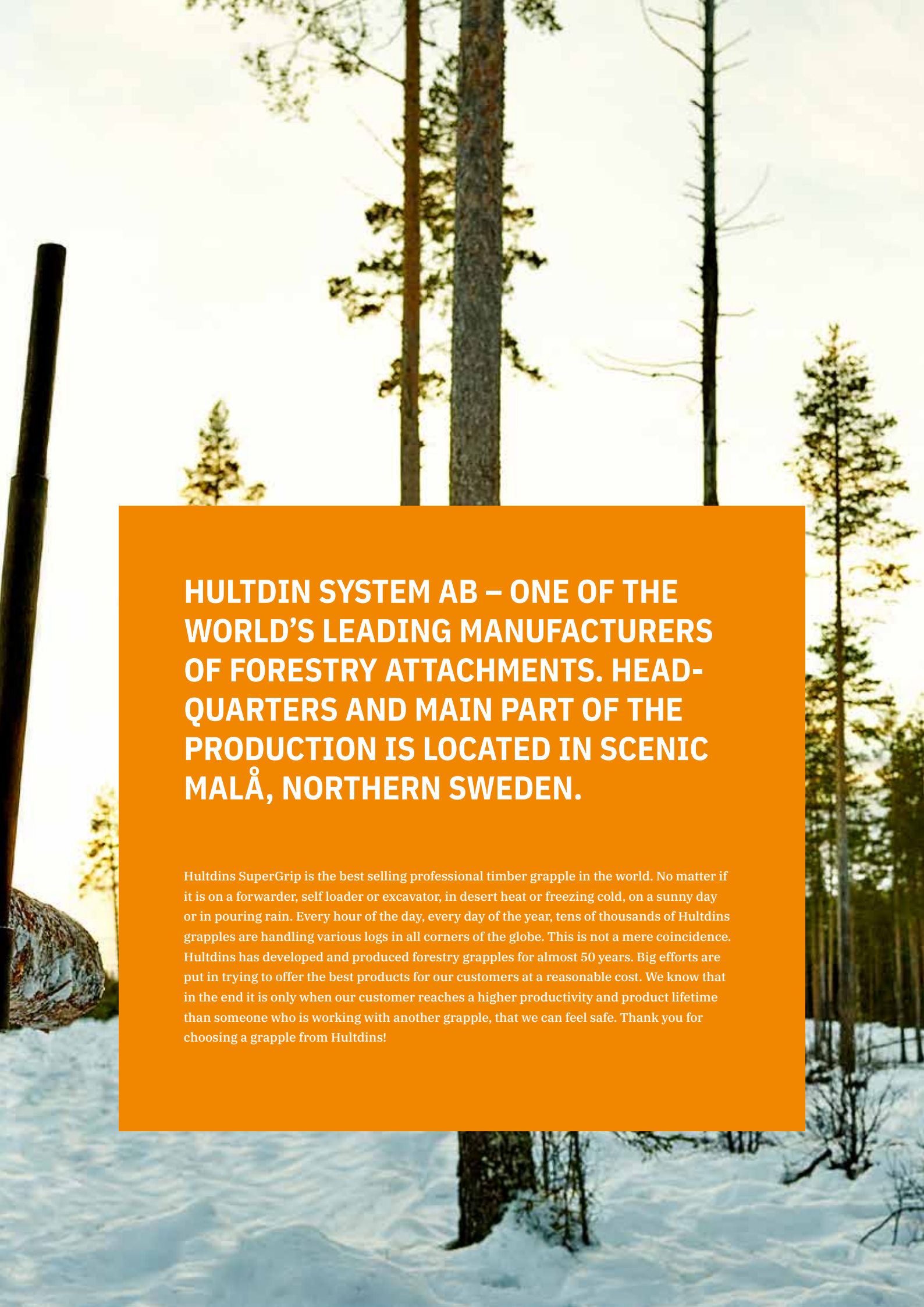

SuperGrip[®]

BY HULTDINS



A photograph of a snowy forest. In the foreground, a large, rough-textured log lies on the snow. Several tall, thin pine trees stand in the background against a bright, overcast sky. The ground is covered in a thick layer of snow.

HULTDIN SYSTEM AB – ONE OF THE WORLD’S LEADING MANUFACTURERS OF FORESTRY ATTACHMENTS. HEAD- QUARTERS AND MAIN PART OF THE PRODUCTION IS LOCATED IN SCENIC MALÅ, NORTHERN SWEDEN.

Hulldins SuperGrip is the best selling professional timber grapple in the world. No matter if it is on a forwarder, self loader or excavator, in desert heat or freezing cold, on a sunny day or in pouring rain. Every hour of the day, every day of the year, tens of thousands of Hulldins grapples are handling various logs in all corners of the globe. This is not a mere coincidence. Hulldins has developed and produced forestry grapples for almost 50 years. Big efforts are put in trying to offer the best products for our customers at a reasonable cost. We know that in the end it is only when our customer reaches a higher productivity and product lifetime than someone who is working with another grapple, that we can feel safe. Thank you for choosing a grapple from Hulldins!



SUPERGRIP

Features

- Tapered sleeve pin design eliminates any joint motion
- Strong cushioned cylinder reduces shock loads, designed for up to 25 MPa working pressure
- High strength steel and robotized welding ensures minimized down time
- Grapple saw option available on all models

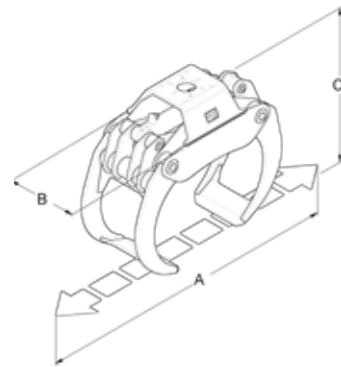

		260	300	360	420	520
Weight	kg	187	188	306	328	360
Max. load	kg	3 500	3 500	5 000	5 000	5 500
Gripping area	m ²	0,26	0,30	0,36	0,42	0,52
Max. gripping width, A	mm	1 525	1 480	1 870	2 075	2 279
Max. width, B	mm	430	430	510	510	514
Height, arms tip-tip, C	mm	867	910	962	1 040	1 152
Max. height arms open	mm	760	803	800	831	887
Min. height arms closed	mm	550	560	627	668	753
Grapple jaw width	mm	384	384	452	460	456
Min. gripping diameter	mm	90	91	110	120	170
Gripping force, arms open, at 25 MPa	kN	10,9	10,4	18,5	19,4	20,9
Gripping force, arms tip-tip, at 25 MPa	kN	15,1	14,6	19,2	20,0	23,1
Opening time, at 50 l/min	s	0,9	0,9	1,6	2,1	2,2
Closing time, at 50 l/min	s	1,7	1,7	2,6	3,5	3,7
Max. operating pressure	MPa	25	25	25	25	25



SUPERGRIP -S

Features

- Heavily reinforced model for the toughest jobs in the forest and excavator applications
- Tapered sleeve pin design eliminates any joint motion
- Strong cushioned cylinder reduces shock loads, designed for up to 25 MPa working pressure
- Strong casted push rods
- Grapple saw option available on all models

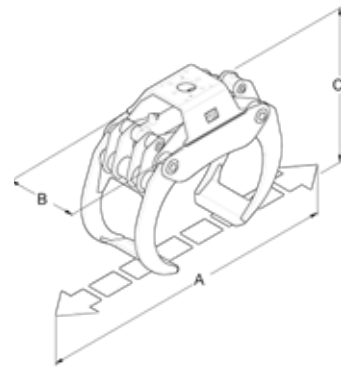

		260S	300S	360S	420S	500S	520S	720S
Weight	kg	233	235	380	408	434	473	516
Max. load	kg	4 500	4 500	8 000	8 000	8 000	8 000	8 000
Gripping area	m ²	0,26	0,30	0,36	0,42	0,50	0,52	0,72
Max. gripping width, A	mm	1 525	1 480	1 870	2 011	2 279	2 279	2 290
Max. width, B	mm	430	430	522	514	521	514	511
Height, arms tip-tip, C	mm	867	836	998	1 071	1 152	1 152	1 283
Max. height arms open	mm	760	804	800	889	886	886	1 060
Min. height arms closed	mm	550	560	656	714	753	753	759
Grapple jaw width	mm	384	384	460	480	480	484	500
Min. gripping diameter	mm	90	91	110	122	153	170	189
Gripping force, arms open, at 25 MPa	kN	10,9	10,4	18,5	19,4	20,9	20,9	17,2
Gripping force, arms tip-tip, at 25 MPa	kN	15,1	14,6	19,2	20,0	23,1	23,1	21,3
Opening time, at 50 l/min	s	0,9	0,9	1,6	2,1	2,2	2,2	2,2
Closing time, at 50 l/min	s	1,7	1,7	2,6	3,5	3,7	3,7	3,7
Max. operating pressure	MPa	25	25	25	25	25	25	25



SUPERGRIP -RS

Features

- Extra heavily reinforced model for the toughest jobs in the forest and excavator applications
- Tapered sleeve pin design eliminates any joint motion
- Strong casted push rod
- Strong cushioned cylinder reduces shock loads, designed for up to 25 MPa working pressure
- Grapple saw option available on all models

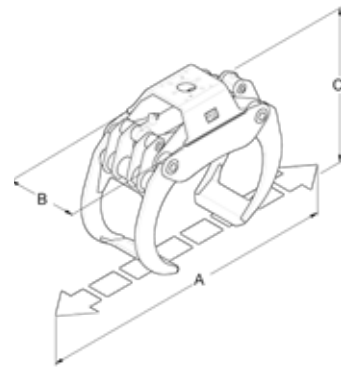

		260RS	300RS	360RS
Weight	kg	266	272	402
Max. load	kg	4 500	4 500	8 000
Gripping area	m ²	0,26	0,30	0,36
Max. gripping width, A	mm	1 525	1 480	1 870
Max. width, B	mm	430	430	522
Height, arms tip-tip, C	mm	867	836	998
Max. height arms open	mm	760	804	800
Min. height arms closed	mm	550	560	656
Grapple jaw width	mm	424	424	484
Min. gripping diameter	mm	90	91	110
Gripping force, arms open, at 25 MPa	kN	10,9	10,4	18,5
Gripping force, arms tip-tip, at 25 MPa	kN	15,1	14,6	19,2
Opening time, at 50 l/min	s	0,9	0,9	1,6
Closing time, at 50 l/min	s	1,7	1,7	2,6
Max. operating pressure	MPa	25	25	25



SUPERGRIP -R

Features

- For handling of slash and bioenergy wood
- Tapered sleeve pin design eliminates any joint motion
- Strong cushioned cylinder reduces shock loads, designed for up to 25 MPa working pressure
- High strength steel and robotized welding ensures minimized down time

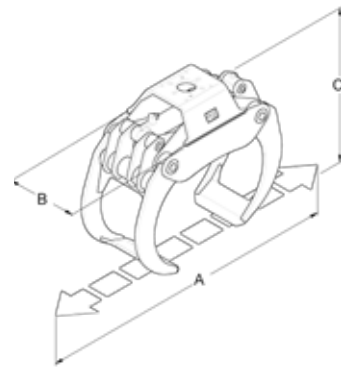

		260R	300R	360R	420R	520R
Weight	kg	210	217	338	371	410
Max. load	kg	3 000	3 000	4 000	4 000	4 500
Gripping area	m ²	0,26	0,30	0,36	0,42	0,52
Max. gripping width, A	mm	1 525	1 480	1 870	2 075	2 279
Max. width, B	mm	430	430	510	510	514
Height, arms tip-tip, C	mm	851	888	953	1 023	1 120
Max. height arms open	mm	742	794	784	809	816
Min. height arms closed	mm	565	565	638	671	757
Grapple jaw width	mm	416	416	492	500	506
Min. gripping diameter	mm	90	91	110	120	170
Gripping force, arms open, at 25 MPa	kN	10,9	10,4	18,5	19,4	20,9
Gripping force, arms tip-tip, at 25 MPa	kN	15,1	14,6	19,2	20,0	23,1
Opening time, at 50 l/min	s	0,9	0,9	1,6	2,1	2,2
Closing time, at 50 l/min	s	1,7	1,7	2,6	3,5	3,7
Max. operating pressure	Mpa	25	25	25	25	25



SUPERGRIP RG -V

Features

- Synchronized arms for a more controlled and efficient handling of ties and rails.
- Grapple is constructed with “High Strength” and “Wear Resistant” Steel.
- Cylinder is equipped with a direct mounted “Load Holding Valve”.
- Cushioned Cylinder to reduce shock load.
- Tapered sleeve pin design eliminates any possible joint motion.
- Grapple Saw Option Available.

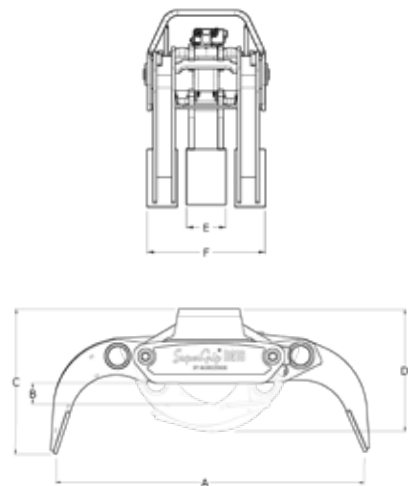

RG16 -V

Weight	lb	(kg)	860	(390)
Max. opening, "A"	inches	(mm)	69,6	(1 768)
Min. opening, "B"	inches	(mm)	4,8	(122)
Max. height, arms open "C"	inches	(mm)	32,6	(829)
Max. height, arms closed "D"	inches	(mm)	29,1	(740)
Width, male arm "E"	inches	(mm)	6,5	(165)
Width, female arm "F"	inches	(mm)	19,5	(496)



SUPERGRIP RG

Features

- Synchronized arms for a more controlled and efficient handling of ties and rails.
- Grapple is constructed with “High Strength” and “Wear Resistant” Steel.
- Cylinder is equipped with a direct mounted “Load Holding Valve”.
- Cushioned Cylinder to reduce shock load.
- Tapered sleeve pin design eliminates any possible joint motion.
- Grapple Saw Option Available.

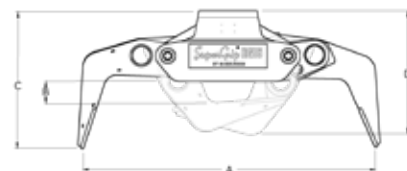
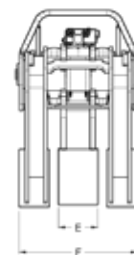

RG16

	lb	(kg)	870	(398)
Weight				
Max. opening, “A”	inches	(mm)	69,6	(1 768)
Min. opening, “B”	inches	(mm)	5,3	(135)
Max. height, arms open “C”	inches	(mm)	32,6	(829)
Max. height, arms closed “D”	inches	(mm)	29,1	(740)
Width, male arm “E”	inches	(mm)	6,5	(165)
Width, female arm “F”	inches	(mm)	19,5	(496)



YOUR PRODUCTIVITY - OUR DRIVING FORCE

Hultdin System AB is a world leading manufacturer of components to mechanized forestry. With the productivity and profitability of our customers in focus we have over the years developed a wide product range consisting of Grapples, Saw Units, Grapple Saws, Damping and Lubrication Systems for forestry machines.



SuperGrip®

Hultdins' log grapples are divided into three series, each with slightly different characteristics. However, common to all is that they're designed to increase your productivity and every component is of high quality. Today, our grapples are fitted as standard by many major forwarder manufacturers.



SuperCut®

Today, every other tree in the world is harvested with a Hultdins SuperCut – and that says a lot about the knowledge we've accumulated over the years. Our goal is to make your work as painless as possible. We try to achieve this with innovative solutions, such as automatic chain tensioning, fully protected feed cylinders, and integrated proportional chain lubrication.



SuperSaw®

The majority of our grapple saws are used for full tree harvesting but also for clearance and maintenance. Hultdins' grapple saws are the most dominant brand by far. With six different grapple saw series, each encompassing several models, we have the market's widest range.



DampingSystem™

A hydraulic damper enables you to work faster and improves the machine's service life – as well as your health. Hydraulic oil is an excellent means to use cylinders to transfer force because it's so incompressible. But this incompressibility also means that it transmits vibrations and jolts that fatigue both the machine and the operator. Our dampers reduce these undesirable forces without affecting the machine's performance.



LubricationSystem™

Oil almost always soils both the forest and the machine. Our pumps use biodegradable chain grease instead, which adheres better between the chain and the bar.



SuperGrip



SuperSaw



SuperCut



DampingSystem



LubricationSystem

Hultdin System AB is a leading manufacturer of tools and integrated components for forestry and construction machines. Hultdins products such as the SuperGrip, SuperSaw and SuperCut are used throughout the world. Ever since 1928, we've been developing products to make machine contractors productive. We try to meet the needs of today while predicting the needs of tomorrow. This is something we can do best by working in the forest in both practice and theory.

Hultdin System AB
Box 100
Skolgatan 12
SE-939 31 Malå
+46 953 418 00
sales@hultdins.se

 **HULTDINS**

hultdins.se

